

Air Nozzles and Jets

Engineered Air Nozzles and Jets reduce noise levels and air costs.

"Go Green" by upgrading your blowoff, cooling and drying operation to the award winning Super Air Nozzles!



What Are Air Nozzles and Jets?

A simple solution to reduce excessive air consumption and noise levels on compressed air blowoff operations. EXAIR Air Nozzles and Jets produce outlet flows up to 25 times compressed air consumption using a small amount of compressed air as the power source. Many power companies now provide attractive rebates to plants who switch to engineered Super Air Nozzles!



Why Air Nozzles and Jets?

Air savings, compared to open copper tubes or pipes commonly used for blowoff, can be as high as 80%. Less compressed air means less noise. The typical noise level reduction is 10 dBA. All EXAIR Air Nozzles and Jets meet Occupational Safety and Health Administration (OSHA) maximum dead end pressure and sound level exposure requirements and carry the CE mark.

An open 1/4" (6mm) copper tube, by contrast, ejects pure compressed air at up to 40 SCFM (1,133 SLPM), the entire output of a 10 horsepower compressor. Annual energy cost can exceed \$1,000 per year. Noise levels in excess of 100 dBA are commonly produced. When supply pressure exceeds 30 PSIG (2 BAR), an open pipe, tube or drilled holes violates OSHA static pressure requirements.



Flexible Stay Set Hoses™ are ideal where frequent repositioning of air nozzles is required.



This PEEK material Atto Super Air Nozzle was chosen because of its non-marring quality for a blow off application on a sensitive lens.

Applications

- Part cleaning
- Chip removal
- Part drying
- Liquid blowoff
- Part cooling
- Material conveying
- Part ejection
- Fiber conveying
- Air assist

Advantages

- Reduced compressed air cost
- 10 dBA average noise reduction
- Conserve compressed air
- Improved blowoff performance
- Compact
- Improved safety
- Meets OSHA noise level requirements
- Meets OSHA pressure requirements
- Improved production

Safe And Efficient Use Of Compressed Air

The inefficient use of compressed air for blowoff applications may create problems due to the energy costs, noise level and potential danger to personnel who are exposed to high pressure air. Open air pipes, copper tubes and drilled pipes are a few of the common abusers. They consume tremendous amounts of energy and often produce noise levels over 100 dBA.

Open Air Pipe or Copper Tube



Turbulent compressed air blasts straight out of the pipe or tube. It not only wastes huge amounts of compressed air but also violates OSHA noise and dead end pressure requirements.

Reduce Energy Costs

The best way to cut energy costs is through proper maintenance and use of the compressed air system. Leaks and dirty filters require maintenance on a regular basis. Energy savings can also be realized when replacing outdated compressor motors and controls with high efficiency models that often pay for themselves in a short period of time.

The most important factor to dramatically boost efficiency is proper use. Using engineered products like EXAIR's Super Air Nozzles can cut operating costs since they use only a fraction of the compressed air of typical blowoffs. In addition, all of the Air Nozzles and Jets shown in this catalog can be cycled on and off with an instantaneous response. EXAIR's EFC (shown on page 7) is an electronic flow control that limits compressed air use by turning on the air only when a part is present.

Reduce Noise Levels

High noise levels are a common problem for many plants. Compressed air noise often exceeds OSHA noise level exposure requirements, resulting in hearing loss to those working in close proximity. Noisy blowoffs at 80 PSIG (5.5 BAR) that produce noise levels of 100 dBA can be reduced to only 74 dBA when using a Super Air Nozzle. At that pressure, it is still possible to obtain hard-hitting force without the high noise.

OSHA Maximum Allowable Noise Exposure

Hours per day (constant noise)	8	7	4	3	2	1	0.5
Sound level dBA	90	91	95	97	100	105	110

OSHA Standard 29 CFR - 1910.95 (a)

Eliminate Harmful Dead End Pressures

Air can be dangerous when the outlet pressure of a hole, hose or copper tube is higher than 30 PSIG (2 BAR). In the event the opening is blocked by a hand or other body part, air may enter the bloodstream through the skin, resulting in a serious injury. All of the Air Nozzles and Jets manufactured by EXAIR have been designed for safety. All are safe to be supplied with higher pressure compressed air and meet OSHA standard 29 CFR 1910.242(b).

Air Consumption of Open Tube And Pipe

Pressure Supply		Air Consumption of Homemade Blowoffs						
PSIG	BAR		Copper Tube			Open Pipe		
			1/4"	5/16"	3/8"	1/8"	1/4"	3/8"
80	5.5	SCFM	33	58	87	70	140	240
		SLPM	934	1,641	2,462	1,981	3,962	6,792

Saving Money and Compressed Air

The table above shows the air consumption for typical homemade blowoffs. The pages that follow give the air consumption and other data on EXAIR's Air Nozzles and Jets.

Consider the following example where a Model 1102 Mini Super Air Nozzle replaces an 1/8" open pipe. The compressed air savings is easy to calculate and proves to be dramatic. Payout for Air Nozzles and Jets, including filter and installation cost is measured in weeks - not years, as is the case for other cost reduction equipment. Based on a 40 hour work week, 52 weeks a year.

Example:

- Existing blowoff is 1/8" open pipe at 80 PSIG (5.5 BAR) supply. Air consumption, from the table above, is 70 SCFM (1,981 SLPM).
- Use a 1/8 FNPT Model 1102 Mini Super Air Nozzle also at 80 PSIG (5.5 BAR) supply. Air consumption, from the table on page 52, is 10 SCFM (283 SLPM).
- Compressed air saved = 70 - 10 = 60 SCFM (1,981 - 283 = 1,698 SLPM)
- For this example, the blowoff is continuous. If the duty cycle was 20%, then air saved would be 60 x .2 = 12 SCFM (1,698 x .2 = 340 SLPM).
- Most large plants know their cost per 1,000 standard cubic feet of compressed air (10,000 standard liters). If you don't know your actual cost per 1,000 SCF, \$0.25 is a reasonable average to use. (Cost per 10,000 standard liters is approximately \$0.089.)
- Dollars saved per hour = SCFM saved x 60 minutes x cost/1,000 SCF (SLPM saved x 60 min x cost/10,000 SL)

$$= 60 \times 60 \times \$0.25/1,000 (= 1,698 \times 60 \times \$0.089/10,000)$$

= \$0.90/hour
= \$0.90/hr. is \$36.00/week and
= \$1,872.00/year savings for One nozzle!

How Air Nozzles Work

Air Nozzles use the Coanda effect to amplify compressed airflow up to 25 times or more. As illustrated on the right, compressed air (black arrows) is ejected through a series of nozzles on the outer perimeter. As the air travels along the outer wall of the nozzle, surrounding air (blue arrows) is entrained into the stream. The airstream that results is a high volume, high velocity blast of air **at minimal consumption**. The air is always ejected so it can vent safely, **well below OSHA dead end pressure requirements**, should the nozzle end be blocked.

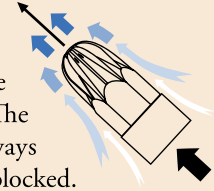

Selecting The Right Air Nozzle

EXAIR manufactures a wide selection of Air Nozzles and Jets, which are divided into two groups. The first group includes Air Nozzles and Jets that deliver force up to 22 ounces (624 grams) and are suitable for most applications. The second group includes Air Nozzles that produce high force up to 23 lbs (10.43 kg) where additional reach and force are required.

- **Type 303 Stainless Steel**- high temperatures and corrosive environments. Max temp 800°F (426°C)
- **Type 316 Stainless Steel**- high temperatures, corrosive environments, and mechanical wear. Max temp 1000°F (538°C)
- **Brass**- general purpose applications. Max temp 400°F (204°C)
- **Zinc aluminum alloy**- general purpose applications. Max temp 250°F (121°C)
- **PEEK**- replaces metals in harsh environments. Offers chemical resistance, non-marring. Max temp 320°F (160°C)

Air Nozzles And Jets Comparison (sorted by compressed air consumption at 80 PSIG (5.5 BAR))

Model	Material	Description	Inlet	Air Consumption		Force		Sound Level dBA	More Details
				SCFM	SLPM	Ozs	Grams		
1108SS	Stainless Steel - Type 316	Atto Super Air Nozzle	M4 x 0.5	2.5	71	2.0*	56.7	58	p. 53
1108-PEEK	PEEK (Plastic)	Atto Super Air Nozzle	M4 x 0.5	2.5	71	2.0*	56.7	58	p. 53
1108SS-NPT	Stainless Steel - Type 316	Atto Super Air Nozzle	1/8 MNPT	2.5	71	2.0*	56.7	58	p. 53
1108-PEEK-NPT	PEEK (Plastic)	Atto Super Air Nozzle	1/8 MNPT	2.5	71	2.0*	56.7	58	p. 53
1109SS	Stainless Steel - Type 316	Pico Super Air Nozzle	M5 x 0.5	4.9	139	5.0*	141.7	68	p. 53
1109-PEEK	PEEK (Plastic)	Pico Super Air Nozzle	M5 x 0.5	4.9	139	5.0*	141.7	68	p. 53
1109SS-NPT	Stainless Steel - Type 316	Pico Super Air Nozzle	1/8 MNPT	4.9	139	5.0*	141.7	68	p. 53
1109-PEEK-NPT	PEEK (Plastic)	Pico Super Air Nozzle	1/8 MNPT	4.9	139	5.0*	141.7	68	p. 53
1110SS	Stainless Steel - Type 316	Nano Super Air Nozzle	M6 x 0.75	8.3	235	8.1*	230	75	p. 53
1110-PEEK	PEEK (Plastic)	Nano Super Air Nozzle	M6 x 0.75	8.3	235	8.1*	230	75	p. 53
1110SS-NPT	Stainless Steel - Type 316	Nano Super Air Nozzle	1/8 MNPT	8.3	235	8.1*	230	75	p. 53
1110-PEEK-NPT	PEEK (Plastic)	Nano Super Air Nozzle	1/8 MNPT	8.3	235	8.1*	230	75	p. 53
1001	Brass	Safety Air Nozzle	1/8 FNPT	10	283	9*	255	78	p. 58
1102	Zinc Aluminum alloy	Mini Super Air Nozzle	1/8 FNPT	10	283	9*	255	71	p. 54
1102-PEEK	PEEK (Plastic)	Mini Super Air Nozzle	1/8 FNPT	10	283	9*	255	71	p. 54
1102SS	Stainless Steel - Type 316	Mini Super Air Nozzle	1/8 FNPT	10	283	9*	255	71	p. 54
1103	Zinc Aluminum alloy	Mini Super Air Nozzle	1/8 MNPT	10	283	9*	255	71	p. 54
1103SS	Stainless Steel - Type 316	Mini Super Air Nozzle	1/8 MNPT	10	283	9*	255	71	p. 54
1126	Zinc Aluminum alloy	1" Flat Super Air Nozzle	1/8 FNPT	10.5	297	9.8†	278	75	p. 55
1126SS	Stainless Steel - Type 316	1" Flat Super Air Nozzle	1/8 FNPT	10.5	297	9.8†	278	75	p. 55
1010SS	Stainless Steel - Type 303	Micro Air Nozzle	1/8 MNPT	13	368	12*	340	80	p. 53
1009	Aluminum	Adjustable Air Nozzle	1/8 MNPT	13	368	12**	340	79	p. 58
1009SS	Stainless Steel - Type 303	Adjustable Air Nozzle	1/8 MNPT	13	368	12**	340	79	p. 58
1100	Zinc Aluminum alloy	Super Air Nozzle	1/4 FNPT	14	396	13*	368	74	p. 54
1100-PEEK	PEEK (Plastic)	Super Air Nozzle	1/4 FNPT	14	396	13*	368	74	p. 54
1100SS	Stainless Steel - Type 316	Super Air Nozzle	1/4 FNPT	14	396	13*	368	74	p. 54
1101	Zinc Aluminum alloy	Super Air Nozzle	1/4 MNPT	14	396	13*	368	74	p. 54
1101SS	Stainless Steel - Type 316	Super Air Nozzle	1/4 MNPT	14	396	13*	368	74	p. 54
1002	Brass	Safety Air Nozzle	1/4 FNPT	17	481	16*	454	80	p. 58
1002SS	Stainless Steel - Type 303	Safety Air Nozzle	1/4 FNPT	17	481	16*	454	80	p. 58
1003	Brass	Safety Air Nozzle	3/8 FNPT	18	509	18*	510	83	p. 58
6019	Brass	Adjustable Air Jet	1/8 MNPT	18	509	16***	454	83	p. 59
6019SS	Stainless Steel - Type 303	Adjustable Air Jet	1/8 MNPT	18	509	16***	454	83	p. 59
6013	Brass	High Velocity Air Jet	1/8 MNPT	22	622	20†	567	82	p. 59
6013SS	Stainless Steel - Type 303	High Velocity Air Jet	1/8 MNPT	22	622	20†	567	82	p. 59
1122	Zinc Aluminum alloy	2" Flat Super Air Nozzle	1/4 FNPT	22	622	22†	624	77	p. 55
1122SS	Stainless Steel - Type 316	2" Flat Super Air Nozzle	1/4 FNPT	22	622	22†	624	77	p. 55
1144	Zinc Aluminum/Steel	2" Super Air Scraper	1/4 FNPT	22	622	22†	624	77	p. 55
1004SS	Stainless Steel - Type 316	Back Blow Air Nozzle	M4 x 0.5	4.5	127	NA	NA	75	p. 57
1006SS	Stainless Steel - Type 316	Back Blow Air Nozzle	1/4 FNPT	22	622	NA	NA	80	p. 57

For High Force Air Nozzles, see page 61.

* Force measured at 12" (305mm) from target
 ** Force measured at 12" (305mm) from target with a .008" (0.20mm) factory setting
 *** Force measured at 12" (305mm) from target with a .006" (0.15mm) factory setting

All sound levels measured at 3 feet (914mm)
 All measurements taken at 80 PSIG (5.5 BAR)
 † Force measured at 12" (305mm) from target with a .015" (0.38mm) shim installed

FNPT = NPT Female
 MNPT = NPT Male

Atto Super Air Nozzles™



Model 1108SS M4 x 0.5
Material: Type 316 Stainless Steel
Model 1108-PEEK M4 x 0.5
Material: PEEK (plastic)

Model 1108SS, 1108-PEEK, 1108SS-NPT, 1108-PEEK-NPT Atto Super Air Nozzle

EXAIR's Atto Super Air Nozzle delivers the smallest, most precise blowoff. The air pattern for this tiny nozzle is forceful, measuring 1.0" in diameter when positioned 6" away from the surface. The 58 dBA noise level is a fraction of ordinary air nozzles.

Air Consumption		Force*		Sound Level
SCFM	SLPM	Ozs	Grams	dBA
2.5	71	2.0	56.7	58

*Force measured at 12" (305mm) from target.
 Sound level measured at 3' (914mm)
 All measurements taken at 80 PSIG (5.5 BAR)



Model 1108SS-NPT 1/8 NPT male
Material: Type 316 Stainless Steel
Model 1108-PEEK-NPT 1/8 NPT male
Material: PEEK (plastic)

Pico Super Air Nozzles™



Model 1109SS M5 x 0.5
Material: Type 316 Stainless Steel
Model 1109-PEEK M5 x 0.5
Material: PEEK (plastic)

Model 1109SS, 1109-PEEK, 1109SS-NPT, 1109-PEEK-NPT Pico Super Air Nozzle

EXAIR's Pico Super Air Nozzle delivers a precise blowoff with a highly focused, forceful blast of airflow. The narrowly focused air pattern measures 1.3" in diameter at 6" away from the surface. The noise level is only 68 dBA.

Air Consumption		Force*		Sound Level
SCFM	SLPM	Ozs	Grams	dBA
4.9	139	5.0	142	68

*Force measured at 12" (305mm) from target.
 Sound level measured at 3' (914mm)
 All measurements taken at 80 PSIG (5.5 BAR)



Model 1109SS-NPT 1/8 NPT male
Material: Type 316 Stainless Steel
Model 1109-PEEK-NPT 1/8 NPT male
Material: PEEK (plastic)

Nano Super Air Nozzles™



Model 1110SS M6 x 0.75
Material: Type 316 Stainless Steel
Model 1110-PEEK M6 x 0.75
Material: PEEK (plastic)

Model 1110SS, 1110-PEEK, 1110SS-NPT, 1110-PEEK-NPT Nano Super Air Nozzle

EXAIR's Nano Super Air Nozzle delivers a highly focused, forceful blast of airflow. The air pattern for this small nozzle measures 1.5" in diameter at 6" away from the surface. The noise level is a low 75 dBA. Overall length measures only 0.78".

Air Consumption		Force*		Sound Level
SCFM	SLPM	Ozs	Grams	dBA
8.3	235	8.1	230	75

*Force measured at 12" (305mm) from target.
 Sound level measured at 3' (914mm)
 All measurements taken at 80 PSIG (5.5 BAR)



Model 1110SS-NPT 1/8 NPT male
Material: Type 316 Stainless Steel
Model 1110-PEEK-NPT 1/8 NPT male
Material: PEEK (plastic)

Micro Air Nozzle™



Model 1010SS 1/8 NPT male
Material: Type 303 Stainless Steel

Model 1010SS Micro Air Nozzle

EXAIR's Micro Air Nozzle optimizes entrainment for a directed, high volume, high velocity airflow. The compact size permits mounting where space is limited. Sound level and air consumption are low.

Air Consumption		Force*		Sound Level
SCFM	SLPM	Ozs	Grams	dBA
13	368	12	340	80

*Force measured at 12" (305mm) from target.
 Sound level measured at 3' (914mm)
 All measurements taken at 80 PSIG (5.5 BAR)

The Air Nozzles and Jets shown on pages 53 – 59 deliver up to 22 ounces (624 grams) of force, making them suitable for most blowoff, drying and cooling applications. All models shown use a small amount of compressed air to entrain large volumes of surrounding room air. The award winning Super Air Nozzles have been engineered to provide the best performance with low sound levels and high efficiency.

Dimensions and Airflow Patterns

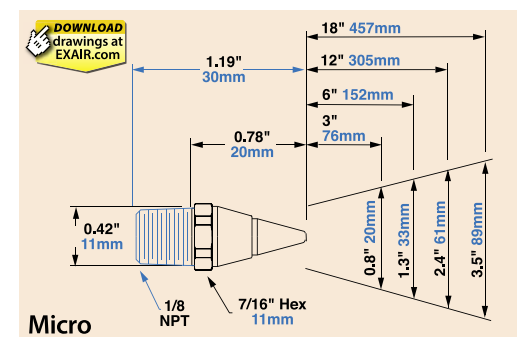
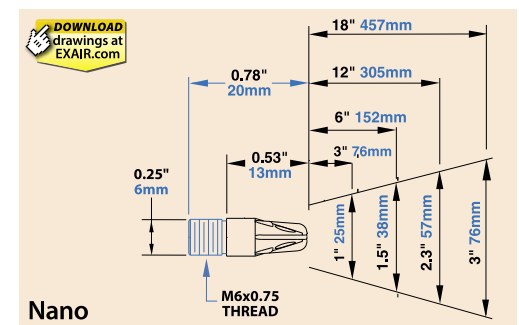
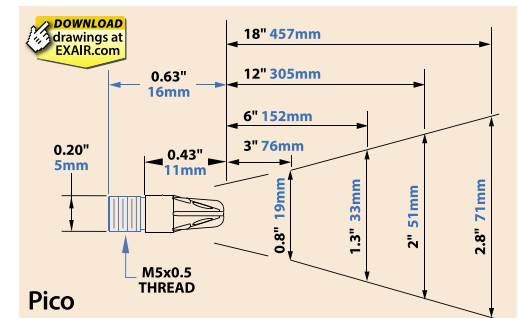
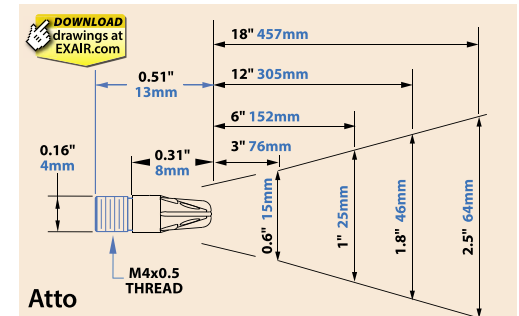

Mini Super Air Nozzles™



- Model 1102** 1/8 NPT female
Material: Zinc Aluminum alloy
- Model 1102-PEEK** 1/8 NPT female
Material: PEEK (plastic)
- Model 1102SS** 1/8 NPT female
Material: Type 316 Stainless Steel

Model 1102, 1102-PEEK, 1102SS, 1103 and 1103SS Mini Super Air Nozzles

The 1/8 NPT Mini Super Air Nozzles provide a forceful, concentrated stream of high velocity airflow. It has fewer holes than the larger Super Air Nozzles, resulting in lower sound levels, air consumption and force.

Air Consumption		Force*		Sound Level
SCFM	SLPM	Ozs	Grams	dBA
10	283	9	255	71

*Force measured at 12" (305mm) from target.
Sound level measured at 3' (914mm)
All measurements taken at 80 PSIG (5.5 BAR)

Dimensions and Airflow Pattern

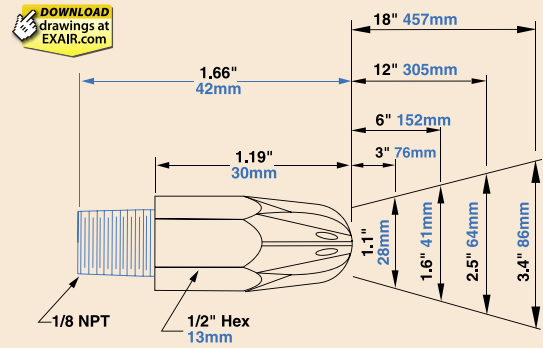

DOWNLOAD drawings at EXAIR.com

Air Nozzles & Jets



- Model 1103** 1/8 NPT male
Material: Zinc Aluminum alloy
- Model 1103SS** 1/8 NPT male
Material: Type 316 Stainless Steel



Super Air Nozzles™



- Model 1100** 1/4 NPT female
Material: Zinc Aluminum alloy
- Model 1100SS** 1/4 NPT female
Material: Type 316 Stainless Steel

Model 1100, 1100SS, 1100-PEEK, 1101 and 1101SS Super Air Nozzles

EXAIR's award winning Super Air Nozzles deliver high performance suitable for a wide range of blowoff, drying and cooling applications. The aerodynamic design of this engineered Super Air Nozzle directs the air to a single point of convergence, delivering hard-hitting force. It dramatically reduces air consumption and, in many cases, can cut the noise level in half. All Super Air Nozzles eject the compressed air through holes located in recessed grooves that can not be blocked or dead ended.



- Model 1100-PEEK** 1/4 NPT female
Material: PEEK (plastic)



- Model 1101** 1/4 NPT male
Material: Zinc Aluminum alloy
- Model 1101SS** 1/4 NPT male
Material: Type 316 Stainless Steel

Dimensions and Airflow Pattern

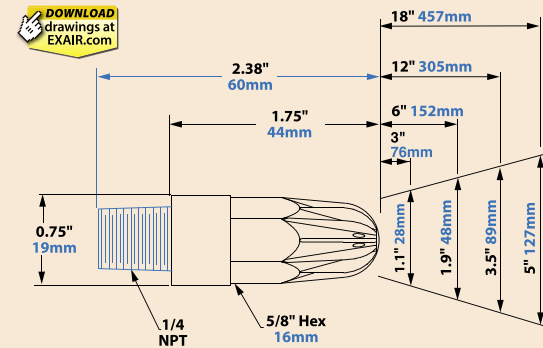

DOWNLOAD drawings at EXAIR.com



Super Air Nozzles with Stay Set Hoses provide adjustability and precision.

Air Consumption		Force*		Sound Level
SCFM	SLPM	Ozs	Grams	dBA
14	396	13	368	74

*Force measured at 12" (305mm) from target
Sound level measured at 3' (914mm)
All measurements taken at 80 PSIG (5.5 BAR)



Most EXAIR Air Nozzles have a standard hex base making them easy to install with a socket wrench.



Build Your Own System

EXAIR's Swivel Fittings, available for all our nozzles up to 1 NPT, make it easy to adjust the aim of the Air Nozzles and Jets. Correct placement of the blowing angle can help optimize performance, reduce noise levels and improve efficiency. See page 66 for details.

Swivel Fittings can be added to most EXAIR Nozzles by adding a "W" to the Model#.

1122 (2" Flat Super Air Nozzle)
+ **W** (Swivel Fitting)

1122W

Flat Super Air Nozzles™



Model 1126 1/8 NPT female
Material: Zinc Aluminum alloy
Model 1126SS 1/8 NPT female
Material: Type 316 Stainless Steel

Shim sets for the 1" Flat Super Air Nozzles include a .005" (0.13mm), .010" (0.25mm), and .020" (0.51mm) thick shim.

1136SS

Stainless Steel 1" Flat Super Air Nozzle Shim Set



Model 1122 1/4 NPT female
Material: Zinc Aluminum alloy
Model 1122SS 1/4 NPT female
Material: Type 316 Stainless Steel

Shim sets for the 2" Flat Super Air Nozzles include a .005" (0.13mm), .010" (0.25mm), and .020" (0.51mm) thick shim.

1132SS

Stainless Steel 2" Flat Super Air Nozzle Shim Set

Model 1126, 1126SS, 1122 and 1122SS 1" and 2" Flat Super Air Nozzles

EXAIR's 1" and 2" Flat Super Air Nozzles are highly efficient, unique flat air nozzles. Their patented† design uses a special shim to maintain the critical position of the component parts. A precise amount of air is released through the thin slot, across a flat surface. The result is a wide, forceful stream of high velocity, laminar airflow with minimal air consumption and noise.

†Patent #5402938

Model	Air Consumption		Force *		Sound Level
	SCFM	SLPM	Ozs	Grams	dBA
1126/1126SS	10.5	297	9.8	278	75

* Force measured at 12" (305mm) from target. Sound level measured at 3' (914mm). All measurements taken at 80 PSIG (5.5 BAR) .015" (0.38mm) shim installed.



1" Flat Super Air Nozzle Airflow Pattern

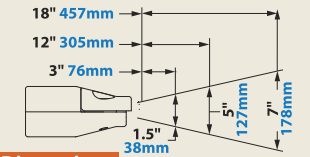

Dimensions

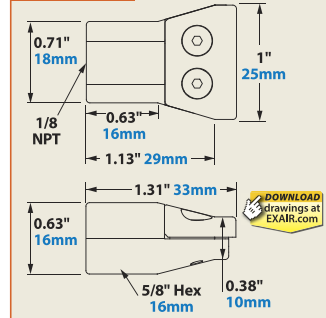

DOWNLOAD drawings at EXAIR.com

Air Nozzles & Jets

The 1" and 2" Flat Super Air Nozzles are shipped with a .015" (0.38mm) air gap opening that is set with a stainless steel shim positioned between the cap and the body. Force and flow may be easily increased or decreased by installing a different shim.

Model	Air Consumption		Force *		Sound Level
	SCFM	SLPM	Ozs	Grams	dBA
1122/1122SS	21.8	622	22	624	77



* Force measured at 12" (305mm) from target. Sound level measured at 3' (914mm). All measurements taken at 80 PSIG (5.5 BAR). .015" (0.38mm) shim installed.

2" Flat Super Air Nozzles blow off metal parts as they are lifted through a vacuum chamber.

2" Flat Super Air Nozzle Airflow Pattern

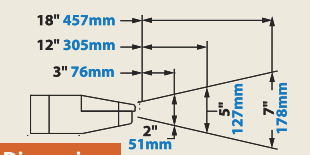

Dimensions

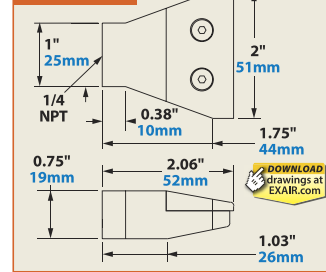

DOWNLOAD drawings at EXAIR.com

Super Air Scraper™



Model 1144 1/4 NPT female
Material: Zinc Aluminum alloy/Steel

Shim sets for the 2" Super Air Scraper include a .005" (0.13mm), .010" (0.25mm), and .020" (0.51mm) thick shim.

1132SS

Stainless Steel 2" Flat Super Air Nozzle Shim Set

Model 1144 2" Super Air Scraper

EXAIR's 2" Super Air Scraper is a patented nozzle used to eliminate stubborn debris from work or machine surfaces. This 2" flat nozzle utilizes a corrosion resistant scraper blade to provide the needed leverage to get underneath and scrape away fixed debris before the air can remove it from a surface. Applications include removal of tape, gaskets, adhesive, labels and stickers, grease, paint and sealant. A scraper nozzle can assist in cleaning sub plates, machining tables and difficult to sweep metal chips, flakes or discs. They are ideal when used upon a Soft Grip Super Air Scraper (see page 103).

†Patent #10,779,698

Model	Air Consumption		Force *		Sound Level
	SCFM	SLPM	Ozs	Grams	dBA
1144	21.8	622	22	624	77

* Force measured at 12" (305mm) from target. Sound level measured at 3' (914mm). All measurements taken at 80 PSIG (5.5 BAR). .015" (0.38mm) shim installed.



2" Super Air Scraper can eliminate stubborn debris.

2" Super Air Scraper Airflow Pattern

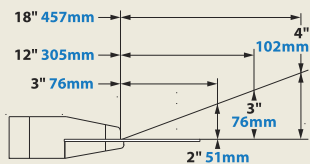

Dimensions

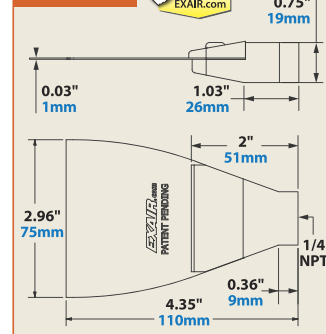

DOWNLOAD drawings at EXAIR.com

EXAIR® Blows Away

the Competition!



Air Nozzles & Jets

**Save Over \$1,200 Per Year
By Replacing One Outdated Air Nozzle!**

We've all seen flat air nozzles. Some are yellow. Others are orange. The oldest ones are blue or metal. Those other manufacturers want you to believe you'll save money by conserving compressed air while protecting your workers from harmful noise levels. In reality, those colorful air nozzles that blow the air out of holes consume enormous amounts of air. The plastic ones often break off. Some might even get you an OSHA fine due to the dangerous dead ended pressures that exist if someone blocks the air exhaust.

EXAIR's award winning 2" Flat Super Air Nozzle™ has been engineered to replace those outdated flat nozzles. There are no dangerous holes that can be blocked. EXAIR's patented, award winning design is efficient, maintaining a precise amount of airflow through a thin slot. The result is a forceful stream of high velocity, laminar airflow with minimal air consumption and noise. You can increase or decrease the force of each flat air nozzle – using shims to tune it to the application so you'll never waste compressed air. EXAIR also offers a 1" Flat Super Air Nozzle™ with the same laminar airflow to fit in tighter spaces.

Flat nozzles from other manufacturers can consume over 30 SCFM (a refrigerator sized compressor) and aren't adjustable. Some manufacturers offer different flow rates but you need to guess at which one will do the job since you can't adjust them once you've made the purchase. By default, most users feel bigger is better and go with the highest flow rate, wasting compressed air. See page 55 for more details.

Here's how:

- One popular flat nozzle consumes 31 SCFM @ 80 PSIG.
- EXAIR's 2" Flat Super Air Nozzle with .015" shim consumes 21.8 SCFM @ 80 PSIG.
- 31 SCFM (theirs) – 21.8 SCFM (EXAIR's) = 9.2 SCFM compressed air saved.

Most large plants know their cost per 1,000 standard cubic feet of compressed air. If you don't know your actual cost per 1,000 SCF, 25¢ is a reasonable average to use.

- SCFM saved x 60 minutes x cost/1,000 SCF = dollars saved per hour.
- In this case, 9.2 SCFM x 60 x .25/1,000 SCF = **13.8 cents saved per hour.**
- 13.8 cents per hour x 24 hours = **\$3.31 saved per day.**
- \$3.31 per day x 365 days = **\$1,208.88 saved in one year** (in this 24/7 operation).

And, This Savings Is For One Nozzle!

Air Nozzle	Air Consumption @ 80 PSIG	Noise Level dBA	lbs. of Force @ 80 PSIG
Yellow	29 SCFM	83	1.7
Orange	28 SCFM	82	1.7
Blue	26 SCFM	78	1.5
Metal (machined)	29 SCFM	82	1.7
Metal (cast)	31 SCFM	80	1.9
EXAIR 2" Flat Super Air Nozzle	*7.3- 30 SCFM	62-81	0.5 – 1.9

*Air consumption dependent upon shim size.

EXAIR's 2" Flat Super Air Nozzle can pay for itself in less than 19 days.

Put the 2" Flat Super Air Nozzle to work in your blowoff, cooling or drying application. We're sure you'll agree that it blows away the competition!

EXAIR's 2" Flat Super Air Nozzle vs. Theirs (Old Technology)

- | | |
|---------------------------------------------------------------------------------------------------------------------------------------------------------------------------------------------------------------------------------------------------------------------------------------------------------------------------------------------------------------------------------|--------------------------------------------------------------------------------------------------------------------------------------------------------------------------------------------------------------------------------------------------------------------------------|
| <ul style="list-style-type: none"> • 2004 Product Of The Year Winner • Your choice of zinc/aluminum or Type 316 stainless steel • Flexible Stay Set Hoses™, swivel fittings and magnetic bases are available • Meets or exceeds OSHA standards • Quietest flat nozzle available • Easy to change the force and flow | <ul style="list-style-type: none"> • Can consume over 30 SCFM • Expensive – metal or plastic • No easy adjustment – wasted compressed air • May not be OSHA safe • Significantly louder • Plastic is easily broken |
|---------------------------------------------------------------------------------------------------------------------------------------------------------------------------------------------------------------------------------------------------------------------------------------------------------------------------------------------------------------------------------|--------------------------------------------------------------------------------------------------------------------------------------------------------------------------------------------------------------------------------------------------------------------------------|



M4 Back Blow Air Nozzle



Model 1004SS M4 x 0.5
Material: Type 316 Stainless Steel

Model 1004SS Air Nozzle

EXAIR's M4 Back Blow Air Nozzle delivers the smallest, most effective airflow for cleaning out small diameter tubes, pipes, channels or holes. Its forceful airflow can be used on diameters as small as 1/4" (6.3mm) and up to 1" (25.4mm). Extensions for reaching farther into a pipe, tube, hose, channel or hole are available.

Model	Air Consumption		Sound Level*	Use With:
	SCFM	SLPM	dBA	Inside Diameters
1004SS	4.5	127	75	1/4" - 1" (6.3-25.4mm)

* Sound level measured at 3' (914mm)

Dimensions and Airflow Pattern

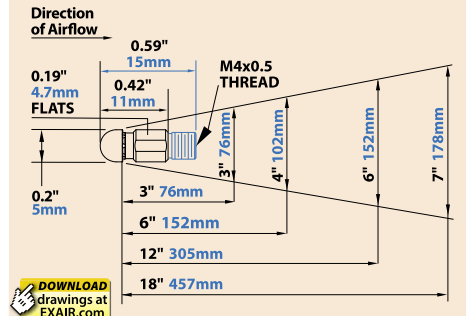

1/4 NPT Back Blow Air Nozzle



Model 1006SS 1/4 NPT female
Material: Type 316 Stainless Steel

Model 1006SS Air Nozzle

The 1/4 NPT Back Blow Air Nozzle delivers high performance suitable for a wide range of diameters. Recommended diameter range is 7/8"-4" (22-102mm). A large variety of extensions for reaching farther into a pipe, tube, hose, channel or hole are available.

Model	Air Consumption		Sound Level*	Use With:
	SCFM	SLPM	dBA	Inside Diameters
1006SS	22	622	80	7/8" - 4" (22-102mm)

* Sound level measured at 3' (914mm)

Dimensions and Airflow Pattern

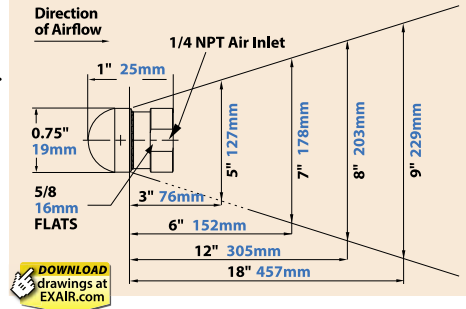

1 NPT Back Blow Air Nozzle



Model 1008SS 1 NPT female
Material: Type 316 Stainless Steel

Model 1008SS Air Nozzle

EXAIR's largest Back Blow Air Nozzle produces the greatest force for stubborn, sticky materials which may be inside of pipes, tubes, channels or holes. It is capable of reaching into diameters from 2"-16" (51-406mm) so it can handle small and large diameters. Extensions are available.

Model	Air Consumption		Sound Level*	Use With:
	SCFM	SLPM	dBA	Inside Diameters
1008SS	57	1,614	89	2" - 16" (51-406mm)

* Sound level measured at 3' (914mm)

Dimensions and Airflow Pattern

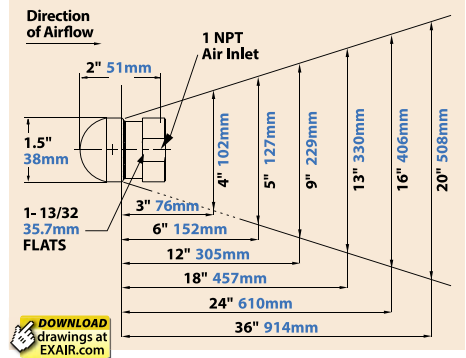

A Back Blow Air Nozzle cleans chips and coolant from inside a machined pipe.

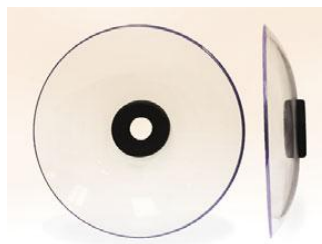

Chip Shields should be used to protect operators from debris. A Model 901650 Chip Shield is for M4 x 0.5 extensions and a Model 901222 is available for 1/4 NPT extensions.

Aluminum Extension Pipe

Extensions provide the necessary reach to clean out your pipe, tube, hose or channel. Available up to 72" (1829mm) long.

Model #	Description
9492	6" (152mm) Aluminum, M4 x 0.5
9493	12" (305mm) Aluminum, M4 x 0.5
9495	24" (610mm) Aluminum, M4 x 0.5
9497	36" (914mm) Aluminum, M4 x 0.5
9188	12" (305mm) Aluminum, 1/4 NPT
9189	18" (457mm) Aluminum, 1/4 NPT
9190	24" (610mm) Aluminum, 1/4 NPT
9191	36" (914mm) Aluminum, 1/4 NPT
9192	48" (1219mm) Aluminum, 1/4 NPT
9193	60" (1524mm) Aluminum, 1/4 NPT
9194	72" (1829mm) Aluminum, 1/4 NPT
900353	12" (305mm) Aluminum, 1 NPT
901254	36" (914mm) Aluminum, 1 NPT
901259	72" (1829mm) Aluminum, 1 NPT

Safety Air Nozzles



Model 1001 1/8 NPT female

Material: Brass

Model 1002 1/4 NPT female

Material: Brass

Model 1002SS 1/4 NPT female

Material: Type 303 Stainless Steel

Model 1003 3/8 NPT female

Material: Brass

Model 1001, 1002, 1002SS and 1003

Safety Air Nozzles

Safety Air Nozzles eject a small amount of compressed air 360° around the outer ring that combines with the air ejected from the center hole to produce a high volume, high velocity blast of air. The slotted end allows air to vent safely should the nozzle end be blocked.

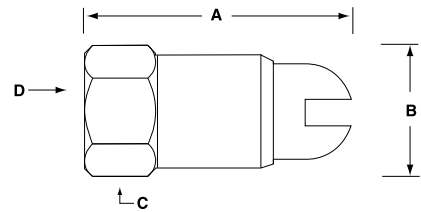

Dimensions		A	B	C	D
Model				Hex	Inlet
1001	in	1.19	0.38	1/2	1/8 NPT
	mm	30	10	13	
1002 1002SS	in	1.44	0.50	5/8	1/4 NPT
	mm	37	13	16	
1003	in	1.65	0.63	3/4	3/8 NPT
	mm	42	16	19	

Air Consumption			Force*		Sound Level
Model	SCFM	SLPM	Ozs	Grams	dBa
1001	10	283	9	255	78
1002	17	481	16	454	80
1002SS	17	481	16	454	80
1003	18	509	18	510	83

* Force measured at 12" (305mm) from target
Sound level measured at 3' (914mm)
All measurements taken at 80 PSIG (5.5 BAR)

Air Nozzles & Jets

Send in your air nozzle

for the Award Winning



Service

We will test your existing product for air use, noise and force. We'll compare it to our Intelligent Compressed Air® products and provide a full report to help improve your process.

Contact an Application Engineer at 1-800-903-9247.

Airflow Pattern

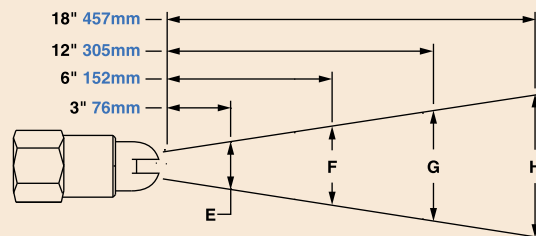

Model		E	F	G	H
1001	in	1.1	2.1	4.1	6.0
	mm	28	53	104	152
1002 1002SS	in	1.3	2.3	4.4	6.5
	mm	33	58	112	165
1003	in	1.3	2.4	4.7	7.0
	mm	33	61	119	178

Adjustable Air Nozzles



Model 1009 1/8 NPT male

Material: Aluminum

Model 1009SS 1/8 NPT male

Material: Type 303 Stainless Steel

Model 1009 and 1009SS

Adjustable Air Nozzles

Adjustable Air Nozzles are suitable for a wide variety of blowoff applications. The design allows you to "tune in" the force and flow to the application requirements, thereby minimizing air consumption. A micrometer-like dial indicates the gap setting. A set screw in the end can be tightened so the air nozzle holds the setting.

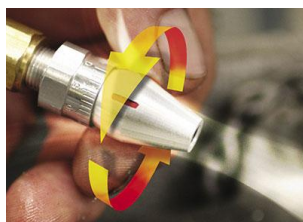

Adjustable Air Nozzles are perfect for a variety of blowoff applications.

Air Consumption		Force*		Sound Level
SCFM	SLPM	Ozs	Grams	dBa
13	368	12	340	79

* Force measured at 12" (305mm) from target with a .008" (0.20mm) factory setting
Sound level measured at 3' (914mm)
All measurements taken at 80 PSIG (5.5 BAR)

Dimensions and Airflow Pattern

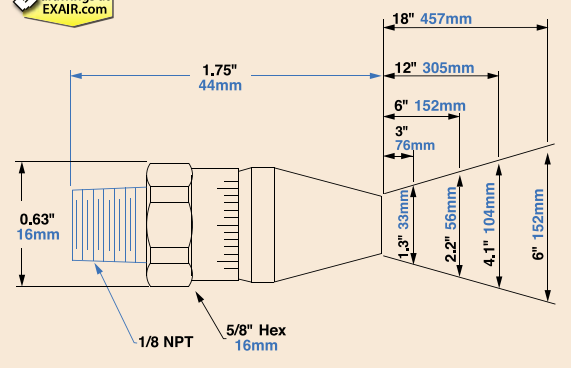

How Air Jets Work

Air Jets utilize the Coanda effect (wall attachment of a high velocity fluid) to produce air motion in their surroundings. As illustrated on the right, a small amount of compressed air (black arrows) is throttled through an internal ring nozzle above sonic velocity. A vacuum is produced, pulling large volumes of surrounding, or “free” air, through the jet (blue arrows). **Both the outlet and inlet can be ducted for remote positioning. If the end is blocked, flow simply reverses at well below OSHA dead end pressure requirements.**

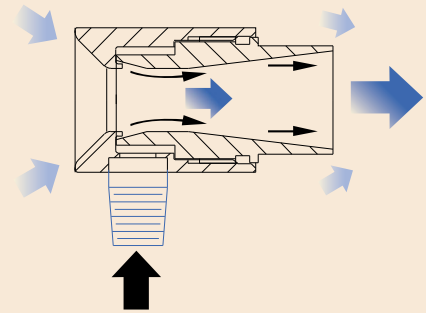

High Velocity Air Jets



Model 6013 1/8 NPT male
Material: Brass
Max Temp: 275°F (135°C)



Model 6013SS 1/8 NPT male
Material: Type 303 Stainless Steel
Max Temp: 400°F (204°C)



Material: Type 303 Stainless Steel

Model 6013 and 6013SS High Velocity Air Jets

Provides maximum thrust with a confined, directed airstream. It is the best choice for part ejection, chip removal, and part drying.

Shim Sets: Shims can be used to change the gap on the Model 6013 and 6013SS High Velocity Air Jets. Changing shims will alter air consumption, force, flow and vacuum capability. Order Model 6313 Air Jet Shim Set.

Air Consumption		Force*		Sound Level
SCFM	SLPM	Ozs	Grams	dBA
22	622	20	567	82

*Force measured at 12" (305mm) from target with a .015" (0.38mm) shim installed
 Sound level measured at 3' (914mm)
 All measurements taken at 80 PSIG (5.5 BAR)

The Model 6313 Air Jet Shim Set for the High Velocity Air Jet includes a .006" (0.15mm) and a .009" (0.23mm) thick shim. A .015" (0.38mm) shim comes installed with the Model 6013 and 6013SS Air Jet.

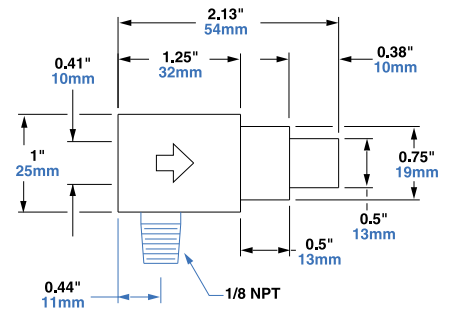

Airflow Pattern

DOWNLOAD drawings at EXAIR.com

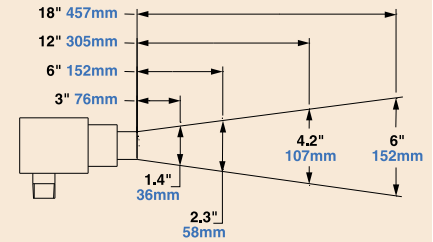

Adjustable Air Jets



Model 6019 1/8 NPT male
Material: Brass
Max Temp: 275°F (135°C)



Model 6019SS 1/8 NPT male
Material: Type 303 Stainless Steel
Max Temp: 400°F (204°C)

Model 6019 and 6019SS Adjustable Air Jets

This is an adjustable version of the Model 6013 High Velocity Air Jet. Airflow and thrust are easily adjusted using the micrometer gap indicator.

Air Consumption		Force*		Sound Level
SCFM	SLPM	Ozs	Grams	dBA
18	509	16	454	83

* Force measured at 12" (305mm) from target with a .006" (0.15mm) setting
 Sound level measured at 3' (914mm)
 All measurements taken at 80 PSIG (5.5 BAR)

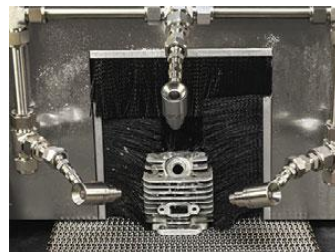

A combination of Model 6013 High Velocity Air Jets dry this chainsaw cylinder head.

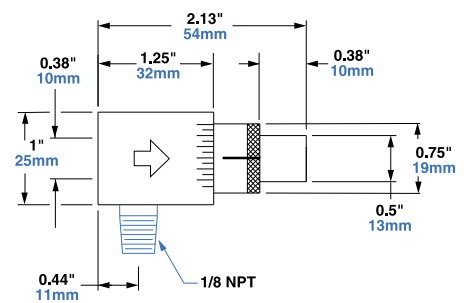

Airflow Pattern

DOWNLOAD drawings at EXAIR.com

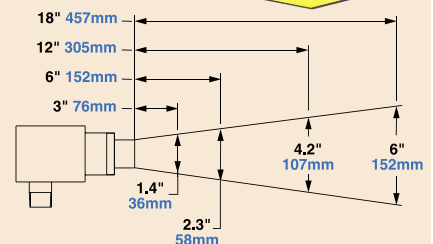

Air Nozzles

How Much Air Does It Really Use?

The amount of compressed air wasted by copper tubes, drilled pipe and other compressed air blowoffs can easily cost thousands of dollars per year. To quantify it, air consumption can be translated into electrical energy use. One horsepower of compressor (746 watts) generates 4 to 5 SCFM (113 to 142 SLPM). The SCFM (SLPM) output depends on the efficiency of the compressor. Wasteful blowoffs can drain the compressed air system where a plant will experience frequent and sizeable pressure drops. The lack of air can be eliminated when the inefficient blowoffs are replaced.

Efficient products like EXAIR's engineered Super Air Nozzles are quiet while being capable of pulling in 25 parts of room air for every one part compressed air. Companies who want to "Go Green" and minimize compressed air use should listen for the loud compressed air noise in their plant. Once the noisy blowoff is located, EXAIR's Digital Sound Level Meter (shown on page 15) can isolate the source and measure the sound level. Replacing one drilled pipe or other homemade blowoff with one Super Air Nozzle can amount to a large air savings. Here's a typical example:



EXAIR's Digital Sound Level Meter detects the source of high noise. (See page 15)

Air Nozzles & Jets

A Steel Plant Reduces Air Use by 59%

A steel plant was using open ended pipes on their cold rolled process to blow away a dense fog of oil vapor so the operator could see the process. Each pipe consumed 195 SCFM (5,521 SLPM) of compressed air. With only a 3:1 air amplification ratio, the open ended pipe did a poor job of clearing the fog. The pipes were dangerous since they could potentially be dead ended (an OSHA violation). Even with hearing protection, workers complained that it was loud.

They installed (2) **Model 1106 1/2 NPT Stainless Steel Super Air Nozzles** with **Model 9069 Swivel Fittings** (to aim them) to blow the fog across the 6' (1.8m) width. The Super Air Nozzles completely cleared the fog and the workers complimented the significant noise drop. **Each open pipe that used to consume 195 SCFM (5,521 SLPM) was reduced to only 60 SCFM (1,699 SLPM) when the Super Air Nozzles were installed.**

Before



After



Digital Flowmeter with USB Data Logger and new wireless models are now available. See pages 10-14 for full details.

Compressed air products should not be used at pressures higher than indicated by the manufacturer since this wastes air. When looking for places to conserve air, it is important to measure the air consumption of everything connected to the compressed air supply rather than relying on the numbers printed in a manufacturer's literature. Some manufacturers of compressed air products understate the air consumption of their products. It is hard to say if it is done intentionally or in error. One possibility is that their flow meter has not been regularly calibrated. Another reason could be a failure to properly use their flow meter.

Most flow meter manufacturers require that any measurement made on their meter be multiplied by a correction factor in order to get the exact air consumption measurement. This takes into account the conditions under which the flow meter was calibrated. If a company using one of these flow meters takes the reading but fails to multiply it by the appropriate correction factor, it would appear their product uses a lot less compressed air – easily half of what it actually consumes. EXAIR's Digital Flowmeter and new wireless models (starting on page 10) are an easy to use solution that does not require regular calibration and provides the actual reading without having to use a correction factor.



High Force Air Nozzles



Some applications require extremely high force with extensive reach. EXAIR offers most standard nozzles in a high force version. With incredibly high blowing forces these nozzles are ideal for part ejection as well as blowoff, cooling and drying applications. EXAIR has engineered Large Super Air Nozzles that put the blowing capability of multiple nozzles into one single air nozzle. Hard-hitting force is measured in pounds, not ounces. All meet OSHA noise level and dead end pressure requirements.

High Force Air Nozzles "Quick Pick" Comparison

High Force Air Nozzles Comparison (sorted by compressed air consumption)

Model	Material	Description	Inlet	Air Consumption at 80 PSIG (5.5 BAR)		Force		Sound Level dBA	More Details
				SCFM	SLPM	Lbs	Grams		
HP1126	Zinc Aluminum alloy	1" High Power Flat Super Air Nozzle	1/8 FNPT	17.5	495	1 [†]	454	82	p. 61
HP1126SS	Stainless Steel - Type 316	1" High Power Flat Super Air Nozzle	1/8 FNPT	17.5	495	1 [†]	454	82	p. 61
HP1002	Brass	High Power Safety Air Nozzle	1/4 FNPT	32	906	1.8*	816	87	p. 62
HP1002SS	Stainless Steel - Type 303	High Power Safety Air Nozzle	1/4 FNPT	32	906	1.8*	816	87	p. 62
1104	Zinc Aluminum alloy	Super Air Nozzle	3/8 FNPT	35	991	1.9*	862	82	p. 62
1104SS	Stainless Steel - Type 316	Super Air Nozzle	3/8 FNPT	35	991	1.9*	862	82	p. 62
1104-PEEK	PEEK (Plastic)	Super Air Nozzle	3/8 FNPT	35	991	1.9*	862	82	p. 62
1105	Zinc Aluminum alloy	Super Air Nozzle	3/8 MNPT	35	991	1.9*	862	82	p. 62
1105SS	Stainless Steel - Type 316	Super Air Nozzle	3/8 MNPT	35	991	1.9*	862	82	p. 62
HP1125	Zinc Aluminum alloy	2" High Power Flat Super Air Nozzle	1/4 FNPT	37	1,039	2.2 [†]	998	83	p. 62
HP1125SS	Stainless Steel - Type 316	2" High Power Flat Super Air Nozzle	1/4 FNPT	37	1,039	2.2 [†]	998	83	p. 62
1111-4	Zinc Aluminum alloy	Super Air Nozzle Cluster	3/8 FNPT	56	1,585	3.2*	1,451	82	p. 65
1008SS	Stainless Steel - Type 316	Back Blow Air Nozzle	1 FNPT	57	1,614	NA	NA	89	p. 57
1106	Zinc Aluminum alloy	Super Air Nozzle	1/2 FNPT	60	1,699	3.3*	1,497	87	p. 63
1106SS	Stainless Steel - Type 316	Super Air Nozzle	1/2 FNPT	60	1,699	3.3*	1,497	87	p. 63
1107	Zinc Aluminum alloy	Super Air Nozzle	1/2 MNPT	60	1,699	3.3*	1,497	87	p. 63
1107SS	Stainless Steel - Type 316	Super Air Nozzle	1/2 MNPT	60	1,699	3.3*	1,497	87	p. 63
1112	Zinc Aluminum alloy	Super Air Nozzle	3/4 FNPT	91	2,577	4.5*	2,041	96	p. 63
1112SS	Stainless Steel - Type 316	Super Air Nozzle	3/4 FNPT	91	2,577	4.5*	2,041	96	p. 63
1113	Zinc Aluminum alloy	Super Air Nozzle	3/4 MNPT	91	2,577	4.5*	2,041	96	p. 63
1113SS	Stainless Steel - Type 316	Super Air Nozzle	3/4 MNPT	91	2,577	4.5*	2,041	96	p. 63
1111-7	Zinc Aluminum alloy	Super Air Nozzle Cluster	1/2 FNPT	98	2,773	5.7*	2,585	85	p. 65
1114	Zinc Aluminum alloy	Super Air Nozzle	1 FNPT	135	3,823	6.6*	3,005	99	p. 63
1114SS	Stainless Steel - Type 316	Super Air Nozzle	1 FNPT	135	3,823	6.6*	3,005	99	p. 63
1115	Zinc Aluminum alloy	Super Air Nozzle	1 MNPT	135	3,823	6.6*	3,005	99	p. 63
1115SS	Stainless Steel - Type 316	Super Air Nozzle	1 MNPT	135	3,823	6.6*	3,005	99	p. 63
1111-12	Zinc Aluminum alloy	Super Air Nozzle Cluster	1 FNPT	168	4,754	9.8*	4,445	89	p. 65
1116	Zinc Aluminum alloy	Super Air Nozzle	1-1/4 FNPT	188	5,324	9.4*	4,252	102	p. 64
1117	Zinc Aluminum alloy	Super Air Nozzle	1-1/4 MNPT	188	5,324	9.4*	4,252	102	p. 64
1118	Zinc Aluminum alloy	Super Air Nozzle	1-1/4 FNPT	300	8,495	15*	6,804	106	p. 64
1119	Zinc Aluminum alloy	Super Air Nozzle	1-1/4 MNPT	300	8,495	15*	6,804	106	p. 64
1120	Zinc Aluminum alloy	Super Air Nozzle	1-1/4 FNPT	460	13,026	23*	10,433	109	p. 64
1121	Zinc Aluminum alloy	Super Air Nozzle	1-1/4 MNPT	460	13,026	23*	10,433	109	p. 64

Air Nozzles & Jets

For Air Nozzles with lower force, see page 52.

* Force measured at 12" (305mm) from target
All sound levels measured at 3 feet (914mm)
All measurements taken at 80 PSIG (5.5 BAR)

† Force measured at 12" (305mm) from target
with a .025" (0.64mm) shim installed.

FNPT = NPT Female
MNPT = NPT Male

1" High Power Flat Super Air Nozzles™



Model HP1126 1/8 NPT female
Material: Zinc Aluminum alloy

Model HP1126SS 1/8 NPT female
Material: Type 316 Stainless Steel



A 1" High Power Flat Super Air Nozzle is used to tip a part from a chute and on to a conveyor.

Model HP1126 and HP1126SS 1" High Power Flat Super Air Nozzles

EXAIR's 1" High Power Flat Super Air Nozzles produce a flat 1" (25mm) wide airstream with a blowing force of 1 pound. The unique design of this super-efficient nozzle makes it an ideal fit for both tight spaces and tight budgets. It uses EXAIR's patented technology to maximize entrained airflow while reducing noise levels.

Air Consumption		Force*		Sound Level
SCFM	SLPM	Lbs	Grams	dBA
17.5	495	1	454	82

* Force measured at 12" (305mm) from target
Sound level measured at 3' (914mm)
All measurements taken at 80 PSIG (5.5 BAR)
.025" (0.64mm) shim installed.

Dimensions and Airflow Pattern

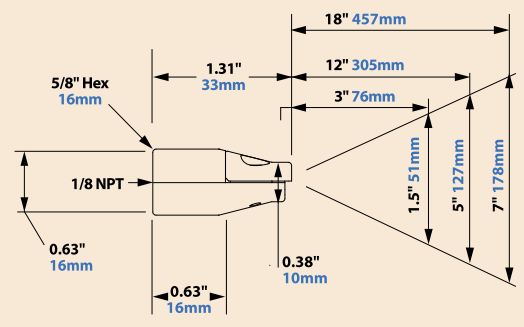

The Model HP1136SS Shim Set for the 1" High Power Flat Super Air Nozzle includes a .020" (0.51mm) and .030" (0.76mm) thick shim. A .025" (0.64mm) shim is installed.

High Power Safety Air Nozzles™



Model HP1002 1/4 NPT female
Material: Brass

Model HP1002SS 1/4 NPT female
Material: Type 303 Stainless Steel

Model HP1002 and HP1002SS High Power Safety Air Nozzles

Provide strong blowing force for applications requiring high thrust and velocity. It uses more compressed air than other air nozzles but is low when compared to typical blowoffs delivering the same force.

Air Consumption		Force*		Sound Level
SCFM	SLPM	Lbs	Grams	dBa
32	906	1.8	816	87

* Force measured at 12" (305mm) from target
Sound level measured at 3' (914mm)
All measurements taken at 80 PSIG (5.5 BAR)

Dimensions and Airflow Pattern

DOWNLOAD
drawings at
EXAIR.com

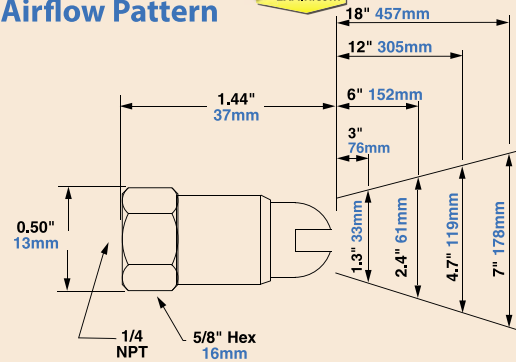

Air Nozzles
& Jets

2" High Power Flat Super Air Nozzles™



Model HP1125 1/4 NPT female
Material: Zinc Aluminum alloy

Model HP1125SS 1/4 NPT female
Material: Type 316 Stainless Steel

Model HP1125 and HP1125SS 2" High Power Flat Super Air Nozzles

EXAIR's 2" High Power Flat Super Air Nozzles produce a flat 2" (51mm) wide air stream with a strong blowing force of 2.2 pounds (998 grams). The adjustable force is more than three times that of ordinary air nozzles. It uses EXAIR's patented† technology to maximize entrained airflow while reducing noise levels.

Air Consumption		Force*		Sound Level
SCFM	SLPM	Lbs	Grams	dBa
37	1,039	2.2	998	83

* Force measured at 12" (305mm) from target.
Sound level measured at 3' (914mm).
All measurements taken at 80 PSIG (5.5 BAR).
.025" (0.64mm) shim installed.

† Patent #5402938

Dimensions and Airflow Pattern

DOWNLOAD
drawings at
EXAIR.com

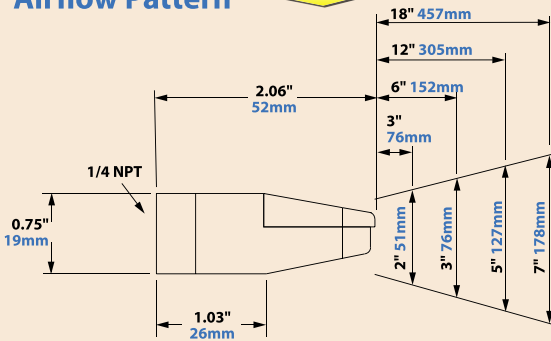

Note: For highest force and flow, order Model 900633 .030" (0.76mm) shim.



The Model HP1132SS Shim Set for the 2" High Power Flat Super Air Nozzle includes a .020" (0.51mm) and .030" (0.76mm) thick shim. A .025" (0.64mm) shim is installed.

Large Super Air Nozzles™



Model 1104 3/8 NPT female
Material: Zinc Aluminum alloy

Model 1104SS 3/8 NPT female
Material: Type 316 Stainless Steel

Model 1104-PEEK 3/8 NPT female
Material: PEEK (plastic)



Model 1105 3/8 NPT male
Material: Zinc Aluminum alloy

Model 1105SS 3/8 NPT male
Material: Type 316 Stainless Steel

Model 1104, 1104SS, 1104-PEEK, 1105 and 1105SS 3/8 NPT Super Air Nozzles

EXAIR's 3/8 NPT Super Air Nozzles produce 1.9 lbs (862 grams) of strong blowing force that is 2.3 times that of the standard Super Air Nozzle. The protective aerodynamic slots guide the airflow to a single point of convergence for hard-hitting force and dramatic noise reduction over typical blowoffs.

Air Consumption		Force*		Sound Level
SCFM	SLPM	Lbs	Grams	dBa
35	991	1.9	862	82

* Force measured at 12" (305mm) from target
Sound level measured at 3' (914mm)
All measurements taken at 80 PSIG (5.5 BAR)

Dimensions and Airflow Pattern

DOWNLOAD
drawings at
EXAIR.com

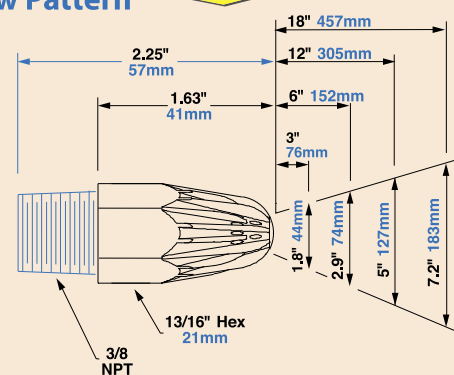

Large Super Air Nozzles™



Model 1106 1/2 NPT female
Material: Zinc Aluminum alloy

Model 1106SS 1/2 NPT female
Material: Type 316 Stainless Steel



Model 1107 1/2 NPT male
Material: Zinc Aluminum alloy

Model 1107SS 1/2 NPT male
Material: Type 316 Stainless Steel

Model 1106, 1106SS, 1107 and 1107SS 1/2 NPT Super Air Nozzles

EXAIR's 1/2 NPT Super Air Nozzles produce 3.3 lbs (1.5 kg) of blowing force – 4 times that of ordinary nozzles. Air consumption and noise are extremely low compared to that of open pipe or copper tubes.

Air Consumption		Force*		Sound Level
SCFM	SLPM	Lbs	Kg	dBA
60	1,699	3.3	1.5	87

* Force measured at 12" (305mm) from target
Sound level measured at 3' (914mm)
All measurements taken at 80 PSIG (5.5 BAR)



Dimensions and Airflow Pattern

DOWNLOAD drawings at EXAIR.com

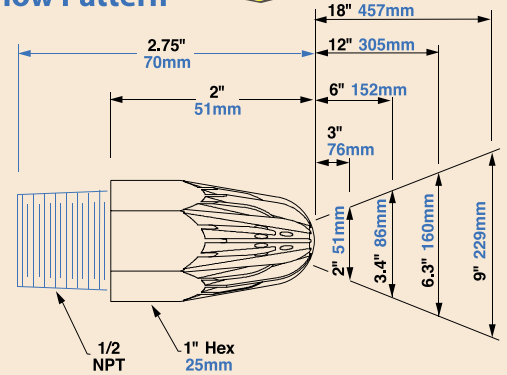

Air Nozzles & Jets



Model 1112 3/4 NPT female
Material: Zinc Aluminum alloy

Model 1112SS 3/4 NPT female
Material: Type 316 Stainless Steel



Model 1113 3/4 NPT male
Material: Zinc Aluminum alloy

Model 1113SS 3/4 NPT male
Material: Type 316 Stainless Steel

Model 1112, 1112SS, 1113 and 1113SS 3/4 NPT Super Air Nozzles

EXAIR's Super Air Nozzles are available in larger sizes where extreme force is required. The 3/4 NPT Super Air Nozzles produce 4.5 lbs (2.04 kg) of blowing force – over 5 times that of ordinary nozzles.

Air Consumption		Force*		Sound Level
SCFM	SLPM	Lbs	Kg	dBA
91	2,577	4.5	2.04	96

* Force measured at 12" (305mm) from target
Sound level measured at 3' (914mm)
All measurements taken at 80 PSIG (5.5 BAR)
OSHA allows 3 hours of exposure per day without hearing protection.

Dimensions and Airflow Pattern

DOWNLOAD drawings at EXAIR.com

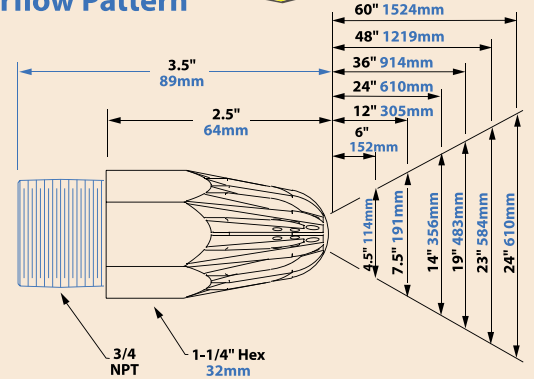

Model 1114 1 NPT female
Material: Zinc Aluminum alloy

Model 1114SS 1 NPT female
Material: Type 316 Stainless Steel



Model 1115 1 NPT male
Material: Zinc Aluminum alloy

Model 1115SS 1 NPT male
Material: Type 316 Stainless Steel

Model 1114, 1114SS, 1115 and 1115SS 1 NPT Super Air Nozzles

EXAIR's 1 NPT Super Air Nozzles optimize entrained airflow across the nozzle surface to minimize the noise level while providing extremely strong blowing force. They produce 6.6 lbs (3.01 kg) of blowing force – over 8 times that of ordinary nozzles.

Air Consumption		Force*		Sound Level
SCFM	SLPM	Lbs	Kg	dBA
135	3,823	6.6	3.01	99

* Force measured at 12" (305mm) from target
Sound level measured at 3' (914mm)
All measurements taken at 80 PSIG (5.5 BAR)
OSHA allows 2 hours of exposure per day without hearing protection.



Dimensions and Airflow Pattern

DOWNLOAD drawings at EXAIR.com

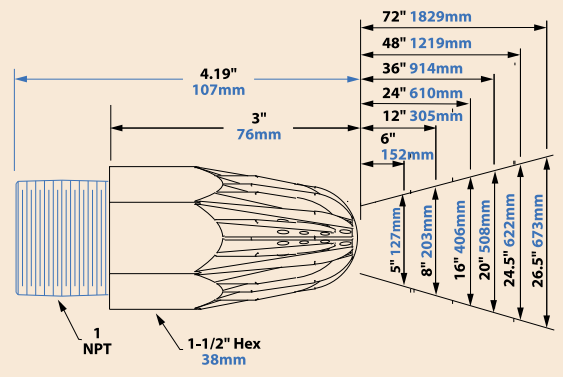

Large Super Air Nozzles™

Model 1116 and 1117

1-1/4 NPT Super Air Nozzles

EXAIR's 1-1/4 NPT Super Air Nozzles provide exceptionally strong blowing force. They produce 9.4 lbs (4.25 kg) of blowing force – almost 12 times that of the standard Super Air Nozzle.

Air Consumption		Force*		Sound Level
SCFM	SLPM	Lbs	Kg	dBa
188	5,324	9.4	4.25	102

* Force measured at 12" (305mm) from target
Sound level measured at 3' (914mm)
All measurements taken at 80 PSIG (5.5 BAR)
OSHA allows 1 hour of exposure per day without hearing protection.



Dimensions and Airflow Pattern

DOWNLOAD drawings at EXAIR.com

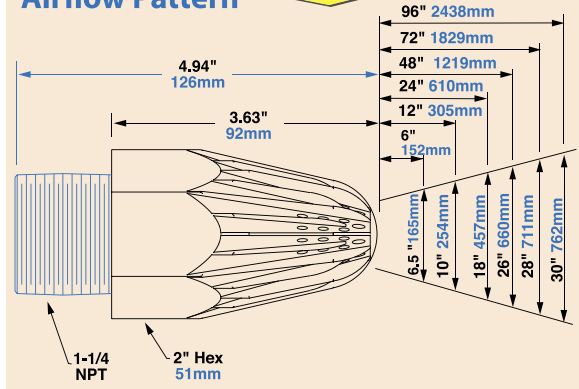

Model 1116 1-1/4 NPT female
Material: Zinc Aluminum alloy



Model 1117 1-1/4 NPT male
Material: Zinc Aluminum alloy

Model 1118 and 1119

1-1/4 NPT Super Air Nozzles

These 1-1/4 NPT Super Air Nozzles have larger orifices than the Model 1116 / 1117 that provide additional air velocity. They generate 15 lbs (6.80 kg) of blowing force – almost 18 times that of the standard Super Air Nozzle.

Air Consumption		Force*		Sound Level
SCFM	SLPM	Lbs	Kg	dBa
300	8,495	15	6.80	106

* Force measured at 12" (305mm) from target
Sound level measured at 3' (914mm)
All measurements taken at 80 PSIG (5.5 BAR)
OSHA allows 1/2 hour of exposure per day without hearing protection.

Dimensions and Airflow Pattern

DOWNLOAD drawings at EXAIR.com

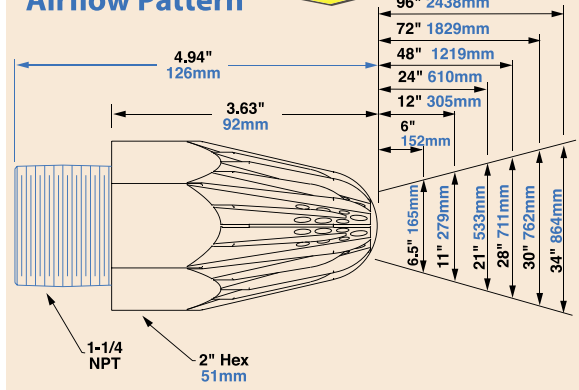

Model 1118 1-1/4 NPT female
Material: Zinc Aluminum alloy



Model 1119 1-1/4 NPT male
Material: Zinc Aluminum alloy

Model 1120 and 1121

1-1/4 NPT Super Air Nozzles

These 1-1/4 NPT Super Air Nozzles have the largest orifices that provide additional air velocity, and generate the strongest blowing force of any single air nozzle. They produce 23 lbs (10.43 kg) of blowing force – almost 28 times that of the standard Super Air Nozzle.

Air Consumption		Force*		Sound Level
SCFM	SLPM	Lbs	Kg	dBa
460	13,026	23	10.43	109

* Force measured at 12" (305mm) from target
Sound level measured at 3' (914mm)
All measurements taken at 80 PSIG (5.5 BAR)
OSHA allows 1/2 hour of exposure per day without hearing protection.

Dimensions and Airflow Pattern

DOWNLOAD drawings at EXAIR.com

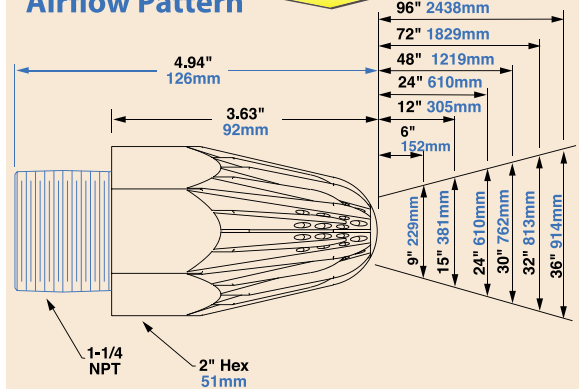

Model 1120 1-1/4 NPT female
Material: Zinc Aluminum alloy



Model 1121 1-1/4 NPT male
Material: Zinc Aluminum alloy



Super Air Nozzle Clusters



Super Air Nozzle Clusters

Model 1111-4 Super Air Nozzle Cluster



Air Consumption		Force*		Sound Level
SCFM	SLPM	Lbs	Kg	dBA
56	1,585	3.2	1.45	82

* Force measured at 12" (305mm) from target
Sound level measured at 3' (914mm)
All measurements taken at 80 PSIG (5.5 BAR)

Model 1111-4 3/8 NPT female
Material: Nozzles - Zinc Aluminum alloy
Body - Aluminum

Dimensions and Airflow Pattern

DOWNLOAD drawings at EXAIR.com

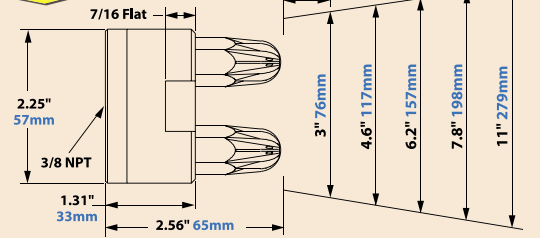

Model 1111-7 Super Air Nozzle Cluster

Air Consumption		Force*		Sound Level
SCFM	SLPM	Lbs	Kg	dBA
98	2,773	5.7	2.59	85

* Force measured at 12" (305mm) from target
Sound level measured at 3' (914mm)
All measurements taken at 80 PSIG (5.5 BAR)

Model 1111-7 1/2 NPT female
Material: Nozzles - Zinc Aluminum alloy
Body - Aluminum

Dimensions and Airflow Pattern

DOWNLOAD drawings at EXAIR.com

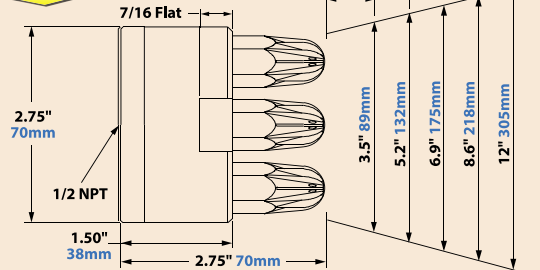

Model 1111-12 Super Air Nozzle Cluster

Air Consumption		Force*		Sound Level
SCFM	SLPM	Lbs	Kg	dBA
168	4,754	9.8	4.45	89

* Force measured at 12" (305mm) from target
Sound level measured at 3' (914mm)
All measurements taken at 80 PSIG (5.5 BAR)

Model 1111-12 1 NPT female
Material: Nozzles - Zinc Aluminum alloy
Body - Aluminum

Dimensions and Airflow Pattern

DOWNLOAD drawings at EXAIR.com

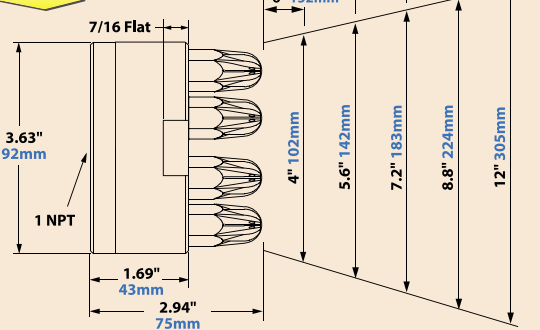

Flexible Stay Set Hoses™

Adding Flexibility

For applications where frequent repositioning of the standard force Air Nozzles or Jets is required, the Flexible Stay Set Hoses™ are ideal. Simply mount the hose in close proximity to the application and bend it to aim the airstream at the target. Since the hose has "memory", it will not creep or bend. It always keeps the aim until physically moved to the next position.

Two versions of the Stay Set Hoses are available in a variety of lengths. The 1/4 MNPT x 1/4 MNPT hose has a 1/4 NPT male fitting on each end and the 1/4 MNPT x 1/8 FNPT hose has a 1/4 NPT male fitting on one end and 1/8 NPT female fitting on the other.



Flexible Stay Set Hoses bend and keep their aim until physically moved.

Flexible Stay Set Hoses™ continued

The Air Nozzles shown below can be used with the following Stay Set Hoses (1/4 NPT male fitting on each end):

Model #	Description	Model #	Description
9206	6" (152mm) 1/4 MNPT x 1/4 MNPT	9224	24" (610mm) 1/4 MNPT x 1/4 MNPT
9212	12" (305mm) 1/4 MNPT x 1/4 MNPT	9230	30" (762mm) 1/4 MNPT x 1/4 MNPT
9218	18" (457mm) 1/4 MNPT x 1/4 MNPT	9236	36" (914mm) 1/4 MNPT x 1/4 MNPT



Model 1002
Safety Air Nozzle



Model 1002SS
SS Safety Air Nozzle

Model HP1002
High Power Safety Air Nozzle

Model HP1002SS
SS High Power Safety Air Nozzle



Model 1122
2" (51mm) Flat Super Air Nozzle

Model 1122SS
2" (51mm) SS Flat Super Air Nozzle

Model HP1122
2" (51mm) High Power Flat Super Air Nozzle

Model HP1122SS
2" (51mm) SS High Power Flat Super Air Nozzle



Model 1100
Super Air Nozzle

Model 1100SS
SS Super Air Nozzle

Model 1100-PEEK
PEEK Super Air Nozzle

Model 1006SS
SS Back Blow Air Nozzle

Air Nozzles & Jets

The Air Nozzles and Jets shown below can be used with the following Stay Set Hoses (1/4 NPT male fitting on one end, 1/8 NPT female on the other):

Model #	Description	Model #	Description
9256	6" (152mm) 1/4 MNPT x 1/8 FNPT	9274	24" (610mm) 1/4 MNPT x 1/8 FNPT
9262	12" (305mm) 1/4 MNPT x 1/8 FNPT	9280	30" (762mm) 1/4 MNPT x 1/8 FNPT
9268	18" (457mm) 1/4 MNPT x 1/8 FNPT	9286	36" (914mm) 1/4 MNPT x 1/8 FNPT



Model 1108SS-NPT
Atto Super Air Nozzle

Model 1108-PEEK-NPT
Atto PEEK Super Air Nozzle

Model 1109SS-NPT
Pico Super Air Nozzle

Model 1109-PEEK-NPT
Pico PEEK Super Air Nozzle

Model 1110SS-NPT
Nano Super Air Nozzle

Model 1110-PEEK-NPT
Nano PEEK Super Air Nozzle



Model 1010SS
SS Micro Air Nozzle



Model 1126 1" (25mm)
Flat Super Air Nozzle

Model 1126SS 1" (25mm)
SS Flat Super Air Nozzle

Model HP1126 1" (25mm)
High Power Flat Super Air Nozzle

Model HP1126SS 1" (25mm)
SS High Power Flat Super Air Nozzle



Model 1103
Mini Super Air Nozzle

Model 1103SS
SS Mini Super Air Nozzle



Model 1009
Adjustable Air Nozzle

Model 1009SS
SS Adjustable Air Nozzle



Model 6013
High Velocity Air Jet

Model 6019
Adjustable Air Jet

Model 6013SS
SS High Velocity Air Jet

Model 6019SS
SS Adjustable Air Jet



Flexible Stay Set Hoses bend to fit your application and will maintain their orientation until the position needs to be re-adjusted. The airstream can be aimed at precisely the correct spot.

Swivel Fittings

Swivel Fittings can be added to most EXAIR Nozzles by adding a "W" to the Model#.



Example:
1122 (2" Flat Super Air Nozzle)
+ W (Swivel Fitting)
1122W

EXAIR's Swivel Fittings make it easy to adjust the aim of the Air Nozzles and Jets. Correct placement of the blowing angle can help optimize performance, reduce noise levels and improve efficiency. Swivel Fittings permit a movement of 25 degrees from the center axis for a total movement of 50 degrees. Type 303 or 316 Stainless Steel.

Swivel Fittings

Model #	Description
9201	M4 x 0.5mm female x 1/8 MNPT, 316SS
9202	M5 x 0.5mm female x 1/8 MNPT, 316SS
9203	M6 x 0.75mm female x 1/8 MNPT, 316SS
9052	1/8 MNPT x 1/8 FNPT, 303SS
9053	1/4 MNPT x 1/4 FNPT, 303SS
9068	3/8 MNPT x 3/8 FNPT, 303SS
9069	1/2 MNPT x 1/2 FNPT, 303SS
9023	3/4 MNPT x 3/4 FNPT, 303SS
9204	1 MNPT x 1 FNPT, 303SS

Magnetic Bases

Magnetic bases are suited to applications where frequent movement of the Air Nozzle or Jet is required. The powerful magnet permits horizontal or vertical mounting that will hold the blowing position of the Stay Set Hose. A shutoff valve is provided that can be used to vary the force and flow.



Model # Description

9042 One Outlet Magnetic Base

9043 Two Outlet Magnetic Base

Build Your Own System

Now you can put together the best combination that suits your blowoff, cooling, drying or cleaning application. Select the model number that includes your choice of Air Nozzle or Jet, a length of Stay Set Hose, and a one or two outlet magnetic base. Here's how:

1. Choose the Air Nozzle or Jet model. **Example:** Model 1100 Super Air Nozzle
2. You have the option to include a length of Stay Set Hose. Simply list the model of the Stay Set Hose (shown on previous page) as a dash number after the Air Nozzle or Jet model number.
Example: A Model 1100 Super Air Nozzle with a Model 9212 12" (305mm) Stay Set Hose is a Model 1100-9212.
3. You have the option to include a magnetic base. If you want a One Outlet Magnetic Base, change the second digit of the "added on" dash number to a "3". If you would like the Two Outlet Magnetic Base, change the second digit to a "4". By using a "4", you will receive (2) Air Nozzles or Jets and (2) Stay Set Hoses to attach to the Two Outlet Magnetic Base.
Example: Two Model 1100 Super Air Nozzles with two 12" (305mm) Stay Set Hoses and Two Outlet Magnetic Base is a Model 1100-9412.



A Model 1100-9412 includes two Model 1100 Super Air Nozzles with two 12" (305mm) Stay Set Hose and Two Outlet Magnetic Base.

Air Nozzles & Jets

Blowoff Kits



Model # 1100-9312
Blowoff Kit includes:
(1) 1100 Super Air Nozzle
(1) 9212 12" (305mm) Stay Set Hose
(1) 9042 Magnetic Base



Model # 1100-9412
Blowoff Kit includes:
(2) 1100 Super Air Nozzles
(2) 9212 12" (305mm) Stay Set Hose
(1) 9043 Magnetic Base



Model # 1103-9362
Blowoff Kit includes:
(1) 1103 Mini Super Air Nozzle
(1) 9262 12" (305mm) Stay Set Hose
(1) 9042 Magnetic Base



Model # 1103-9462
Blowoff Kit includes:
(2) 1103 Mini Super Air Nozzles
(2) 9262 12" (305mm) Stay Set Hose
(1) 9043 Magnetic Base



Model # 1122-9312
Blowoff Kit includes:
(1) 1122 2" Flat Super Air Nozzle
(1) 9212 12" (305mm) Stay Set Hose
(1) 9042 Magnetic Base



Model # 1122-9412
Blowoff Kit includes:
(2) 1122 2" Flat Super Air Nozzles
(2) 9212 12" (305mm) Stay Set Hose
(1) 9043 Magnetic Base



Model # 1909
Blowoff Kit includes:
(1) 1102 Mini Super Air Nozzle
(1) 1009 Adjustable Air Nozzle
(1) 1100 1/4 NPT Super Air Nozzle
(1) 1104 3/8 NPT Super Air Nozzle
(1) 1106 1/2 NPT Super Air Nozzle
(1) 1122 2" Flat Super Air Nozzle
(1) 6013 High Velocity Air Jet
(1) 6019 Adjustable Air Jet



Model # 1909SS
Stainless Steel Blowoff Kit includes:
(1) 1102SS 1/8 NPT Mini Super Air Nozzle
(1) 1009SS Adjustable Air Nozzle
(1) 1100SS 1/4 NPT Super Air Nozzle
(1) 1104SS 3/8 NPT Super Air Nozzle
(1) 1106SS 1/2 NPT Super Air Nozzle
(1) 1010SS 1/8 NPT Micro Air Nozzle
(1) 1122SS 2" Flat Super Air Nozzle



Model # 1910
Instant Blowoff Station includes:
(1) 1100 Super Air Nozzle
(1) 9212 12" (305mm) Stay Set Hose
(1) 9042 Magnetic Base
(1) 9040 Foot Pedal
(2) 900061 10' (3m) Compressed Air Hose

EXAIR® Standards Compliance

As the leader in standards compliance, EXAIR's products come with more than engineered performance, peak efficiency, the best technical knowledge and unmatched customer service... .

EXAIR is dedicated to providing products that have been manufactured to meet the strict requirements of the following standards. These standards provide confidence that you are receiving reliable, high quality products which will perform as stated within the performance charts provided.

Our products meet or exceed the strict safety standards of OSHA and the European Union to ensure the safety of your personnel. Many of these standards will allow your products a smoother transaction when selling your products into international markets.

OSHA and CE Compliance: EXAIR compressed air products comply with OSHA's Safety Requirements (29 CFR 1910.242(b)), the EU General Product Safety Directive (2001/95/EC) and meet the noise limitation requirements (29 CFR-1910.95(a)), of the EU Machinery Directive (2006/42/EC). EXAIR's Electronic Flow Control and Electronic Temperature Control meet the low voltage standards of the EU Low Voltage Directive (2006/95/EC). Some EXAIR products display the CE mark where there are applicable directives. All sound level measurements are taken at 3 feet from product.



RoHS: Electrical portions of EXAIR's Static Eliminators, EFC, ETC, Digital Flowmeter solenoid valves, and thermostats comply with the RoHS (Restriction of Hazardous Substances) Directive 2011/65/EU, including the amendment outlined in the European Commission decision L 214/65.



Conflict Mineral Free: Look for this symbol to designate conflict mineral free products throughout our catalog. EXAIR supports Section 1502 of the Dodd-Frank Wall Street Reform and Consumer Protection Act. We are committed to compliance with the conflict minerals rule in order to curb the illicit trade of tin, tantalum, tungsten and gold in the DRC region. EXAIR is using the CMRT 4.20 template to document our supply chain and commitment to conflict free products.



Reach: Per Regulation (EC) No 1907/2006 Title I, Article 3, paragraph 3, the European Union has recently enacted legislation to register chemicals and substances imported into the EU to ensure a high level of protection of human health and the environment.



Per Title II, Article 7, paragraph 1, articles (products) must be registered when a substance is intended to be released under normal or reasonably foreseeable conditions of use and it is present in those articles in quantities totaling over 1 metric ton per producer or importer per year. Registration of EXAIR products is not required since they do not contain substances that are intentionally released.