



Line Vac



Line Vac™

Convey parts, materials, waste - with no moving parts!

- ✓ High Conveying Rates!
- ✓ Ideal For Long Distance!
- ✓ Mounting Brackets Available!



What Is The Line Vac?

A fast, low cost way to convey:

- Plastic pellets
- Scrap trim
- Textiles
- Bulk solids
- Food products
- Chips
- Paper
- Pills/tablets
- Small parts
- Shavings
- Sawdust
- Granules



Watch the demo!

www.exair.com/lvvideo.htm

EXAIR's compressed air operated Line Vac connects to standard hose or tube to create a powerful in-line conveyor. The compact design features large throat diameters for maximum throughput capability. Eleven sizes in aluminum and ten in stainless steel are suited to a wide variety of transfer applications.

Why The Line Vac?

Line Vac conveyors are ideal for moving large volumes of material over long distances. A small amount of compressed air is injected through directed nozzles to produce a vacuum on one end and high output flows on the other, with instantaneous response. The material flow rate is easily controlled with a pressure regulator. An optional bracket permits easy mounting. No moving parts or electricity assures maintenance free operation.



See page 4 for complete details.

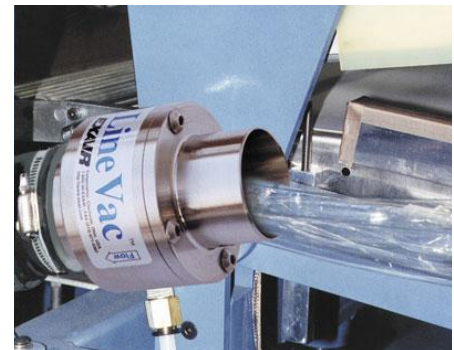

A Model 6084 2" (51mm) Line Vac transports scrap cellophane trim to a waste barrel.

Air Operated Conveyors



The Model 6083 1-1/2" (38mm) Line Vac conveys plastic granules to the gravity feed hopper on an extruder.

Applications

- Hopper loading
- Fiber tensioning
- Material conveying
- Waste/trim removal
- Chip removal
- Part transfer
- Filling operations

Advantages

- Compact
- Quiet
- No moving parts
- Fits standard hose or tube
- Aluminum or stainless steel
- Eleven sizes
- High throughput capability

Line Vac

How The Line Vac Works

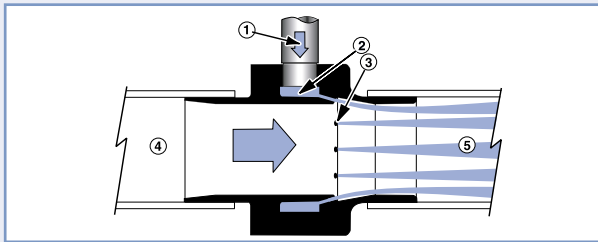

Compressed air flows through the inlet (1) into an annular plenum chamber (2). It is then injected into the throat through directed nozzles (3). These jets of air create a vacuum at the intake (4) which draws material in and accelerates it through the unit (5) for conveying over long vertical or horizontal distances.

Line Vac Conveying Rates

Line Vacs are available in a number of styles, materials, and sizes. Each has a large, smooth, straight bore that allows as much material to pass through as possible. Infinite control of the flow rate through the Line Vac can be controlled by a pressure regulator. Kits include a pressure regulator that is sized properly for flow.

The actual conveying rate is affected by the size, mass and geometry of the part to be conveyed along with the length, lift and number of bends in the hose, tube or pipe. These variables make it difficult to determine the exact conveying rate for any product, however, our Application Engineers can assist you by comparing the material you want to convey with something that has already been tested.



Line Vacs are available in many sizes in both aluminum and stainless steel.

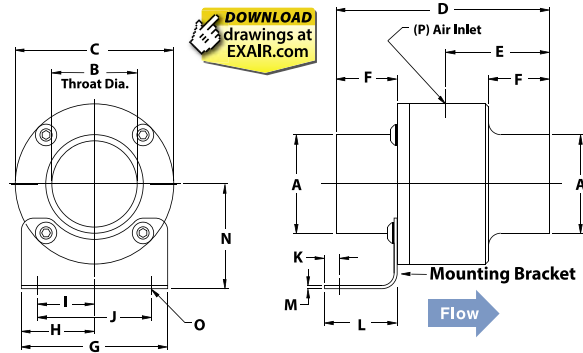

DOWNLOAD drawings at EXAIR.com

Line Vac Dimensions

Line Vac Models			Hose Size																
Alum.	St. St.	Heavy Duty	A	B	C	D	E	F	G	H	I	J	K	L	M	N	O	P	
6078	6058, 6058-316	N/A	in	0.38	0.19	1	2.18	1	0.63	1.25	0.63	0.41	0.82	0.17	1.13	0.06	1.07	0.18	1/8
			mm	10	5	25	55	25	16	32	16	10	21	4	29	2	27	5	NPT
6079	6059, 6059-316	N/A	in	0.50	0.31	1.25	2.62	1.23	0.75	1.25	0.63	0.34	0.68	0.13	1	0.06	1.18	0.18	1/8
			mm	13	8	32	66	31	19	32	16	9	17	3	25	2	30	5	NPT
6080	6060, 6060-316, HT6060, HT6060-316	150075	in	0.75	0.50	1.88	3.88	1.88	1	2	1	0.76	1.52	0.25	1.38	0.06	1.44	0.20	1/4
			mm	19	13	48	99	48	25	51	25	19	39	6	35	2	37	5	NPT
6081	6061, 6061-316, HT6061, HT6061-316	150100	in	1	0.75	2.13	3.88	1.88	1	2	1	0.65	1.30	0.26	1.32	0.06	1.56	0.20	1/4
			mm	25	19	54	99	48	25	51	25	17	33	7	34	2	40	5	NPT
6082	6062, 6062-316, HT6062, HT6062-316	150125	in	1.25	1	2.38	3.88	1.88	1	2.50	1.25	1	2	0.31	1.61	0.06	1.68	0.28	1/4
			mm	32	25	61	99	48	25	64	32	25	51	8	41	2	43	7	NPT
6083	6063, 6063-316, HT6063, HT6063-316	150150	in	1.50	1.25	2.75	4.38	2.13	1.25	2.50	1.25	0.86	1.73	0.25	1.44	0.06	1.88	0.28	3/8
			mm	38	32	70	111	54	32	64	32	22	44	6	37	2	48	7	NPT
6084	6064, 6064-316, HT6064, HT6064-316	150200	in	2	1.75	3.25	4.38	2.13	1.25	3	1.50	1.17	2.34	0.28	1.48	0.06	2.13	0.28	3/8
			mm	51	45	83	111	54	32	76	38	30	59	7	38	2	54	7	NPT
6085	6065, 6065-316, HT6065, HT6065-316	150250	in	2.50	2.25	3.75	4.38	2.13	1.25	3	1.50	1	2	0.31	1.44	0.06	2.38	0.28	3/8
			mm	64	57	95	111	54	32	76	38	25	51	8	37	2	60	7	NPT
6086	6066, 6066-316, HT6066, HT6066-316	150300	in	3	2.75	4.25	5.63	2.75	1.75	3.25	1.63	1.20	2.41	0.41	1.44	0.06	2.63	0.28	1/2
			mm	76	70	108	143	70	45	83	41	31	61	10	37	2	67	7	NPT
6087	6067	N/A	in	4	3.75	5.25	5.63	2.75	1.75	3.25	1.63	1.34	2.70	0.31	1.59	0.06	3.13	0.28	1/2
			mm	102	95	133	143	70	45	83	41	34	69	8	40	2	80	7	NPT
6088	N/A	N/A	in	5	4.75	6.25	5.63	2.75	1.75	4.13	2.06	1.70	3.47	0.33	1.52	0.06	3.63	0.28	1/2
			mm	127	121	159	143	70	45	105	52	43	88	8	39	2	92	7	NPT

Air Operated Conveyors

Line Vac Performance

80 PSIG (5.5 BAR)	Air Consumption		Vacuum		
	Model	SCFM	SLPM	"H ₂ O	kPa
	6058, 6058-316, 6078	5.60	158	-120	-29.9
	6059, 6059-316, 6079	7	198	-100	-24.9
	6060, HT6060, 6060-316, HT6060-316, 6080	10.70	303	-72	-18
	6061, HT6061, 6061-316, HT6061-316, 6081	14.70	416	-42	-11
	6062, HT6062, 6062-316, HT6062-316, 6082	25.90	733	-42	-11
	6063, HT6063, 6063-316, HT6063-316, 6083	33	934	-36.8	-9
	6064, HT6064, 6064-316, HT6064-316, 6084	45	1,274	-28.5	-7
	6065, 6065-316, HT6065, HT6065-316, 6085	58.50	1,656	-23.5	-6
	6066, 6066-316, HT6066, HT6066-316, 6086	68.50	1,939	-14.7	-4
	6067, 6087	95	2,690	-13.6	-3.4
	6088	128	3,625	-10.5	-2.6



Line Vac Kits include a Line Vac, mounting bracket, filter separator and pressure regulator (with coupler).

Sound levels for the individual Line Vac units are not provided. The length, bends and configuration of the hose, tube or pipe used in conjunction with the Line Vac to form the complete conveying system will determine the actual sound levels (which can vary greatly).

Selecting The Right Model

Line Vac is available in a wide range of sizes to fit your application. Some of the criteria used to select the proper model are:

- Diameter of parts being conveyed
- Diameter of hose or tube
- Rate (weight or volume)
- Stainless steel (Type 303 and 316) or aluminum

Aluminum is the economical choice for general purpose conveying. Our standard stainless steel models (Type 303) offer good corrosion resistance and are ideal for food service, abrasive or corrosive applications. For critical applications including certain foods and pharmaceutical products, Type 316 stainless steel models provide excellent corrosion resistance.

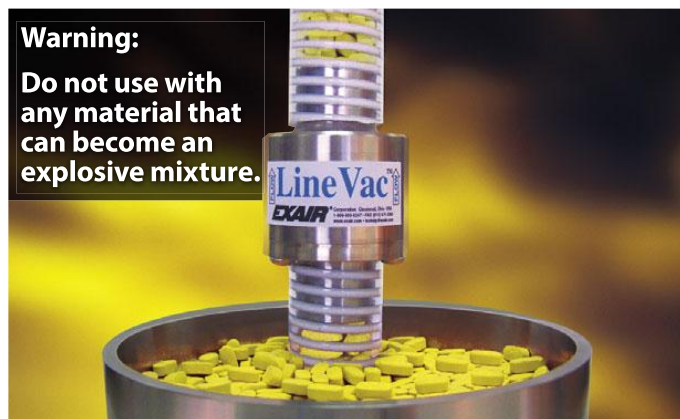

Warning:
Do not use with any material that can become an explosive mixture.

A 316 Stainless Steel Line Vac is used by a pharmaceutical company to convey pills and tablets to a packaging station.

Line Vac Comparison		
Material Type	Temperature Rating	Corrosion Resistance
Aluminum Line Vac	275°F (135°C)	Fair
Stainless Steel Line Vac (Type 303)	400°F (204°C)	Good
Stainless Steel Line Vac (Type 316)	400°F (204°C)	Excellent
High Temperature Stainless Steel Line Vac (Type 303)	900°F (482°C)	Good
High Temperature Stainless Steel Line Vac (Type 316)	900°F (482°C)	Excellent
Heavy Duty Line Vac Hardened Alloy Construction	400°F (204°C)	Good
Flanged Line Vac (Type 316)	400°F (204°C)	Excellent

The High Temperature Line Vac models are suited for temperatures up to 900°F (482°C). Frequently used for sampling hot flue gases, this High Temperature Line Vac can resist back pressure from long pipe lengths with numerous bends. The Heavy Duty Line Vac shown on page 150 moves the highest volumes and resists wear.



High Temperature Line Vacs can resist temperatures to 900°F (482°C) and are available from stock in hose or threaded models.

For assistance with product selection, contact an Application Engineer at 1-800-903-9247.

Line Vac

Clear PVC Hose

EXAIR stocks 3/8" (10mm), 1/2" (13mm), 3/4" (19mm), 1" (25mm), 1-1/4" (32mm), 1-1/2" (38mm), 2" (51mm), 2-1/2" (64mm) and 3" (76mm) I.D. PVC hose in lengths up to 50' (15.2m). Ideal for conveying applications, the hose is very flexible and has a smooth internal bore that eliminates material build up. The reinforced, heavy wall of this clear hose provides visual confirmation that the material is moving when air is supplied to the Line Vac. Temperature rating is -4 to 150°F (-20 to 66°C).



Special Line Vacs

EXAIR manufactures special Line Vacs suited to specific application requirements. Configurations and materials can be made to facilitate your requirements.

The Line Vac can be engineered to retrofit existing machinery. The Line Vac (*shown below*) has special flanges that permit direct mounting to a machine used in the manufacturing of silicon wafers for the semiconductor industry.



A special 3/4" (19mm) Stainless Steel Line Vac evacuates fumes from a silicon wafer etching operation.

This flanged Line Vac is used to remove acidic vapors resulting from surface etching of the silicon wafer. Ordinarily, EXAIR's Stainless Steel Air Amplifier would have been used since it moves much higher volumes of air. In this case, the Line Vac was the better choice since the exhaust piping was long with many bends that would have created high back pressure. The directed nozzles of the Line Vac overcame this downstream resistance.



This special 1-1/2" (38mm) Line Vac is made of PVDF to withstand a chloride washdown.

The special flanged Line Vac (*shown above*) is made of PVDF, a plastic that has high chemical resistance. In this case, the 1-1/2" (38mm) Line Vac was regularly exposed to a chloride wash, a chemical that would corrode stainless steel. QF flanges were provided on each end to allow easy removal of the conveying hoses for cleaning purposes.



This special Line Vac is used to fill small packets.

Filling small packets with fine powders or granulated materials

If you have special requirements, please contact an Application Engineer to discuss the application.

such as salt or sugar is done using small tubes that are gravity fed from a hopper. This works well when the material is dry, however, moist materials would often pack the tube, blocking the flow. The special funnel shaped Line Vac (*shown bottom center*) created a suction on the existing tube to permit continuous product flow.



A special miniature Line Vac used to vacuum microscopic debris measures the same size as a penny!

The special miniature Line Vac with barb fittings (*shown above*) was designed for a manufacturer of integrated circuit chips. It was used to remove microscopic debris during the chip making process. This small Line Vac generated high vacuum and was the perfect configuration for the confined working space. It has also been used by another manufacturer to vacuum liquid and chips from small drilled holes.

Refilling A Vibratory Bowl

The Problem: A manufacturer of metal products deburrs aluminum sleeves in a vibratory bowl filled with abrasive media. As the parts complete the deburring cycle, they are discharged to a screened bed. The abrasive media drops through the bed and the finished parts roll into a box. Refilling the bowl was a back breaking operation that required repetitious lifting of heavy buckets.

The Solution: A **Model 6064 2" (51mm) Stainless Steel Line Vac** was installed on the vibratory bowl. In minutes, the media was conveyed back up to the bowl through a hose, without the heavy lifting.

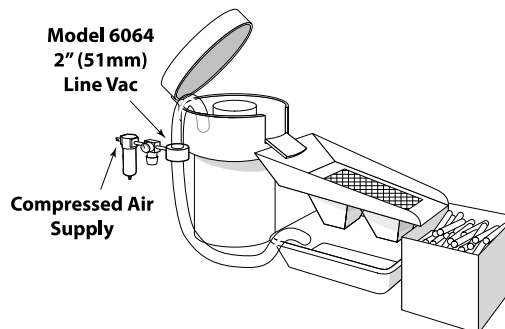

Comment: The ability to convey the abrasive media with air was the key to success. The Line Vac is easy to use, and in this case, was the best choice since it will hold up better to the abrasive media conveyed through it.

Conveying Plastic Pellets

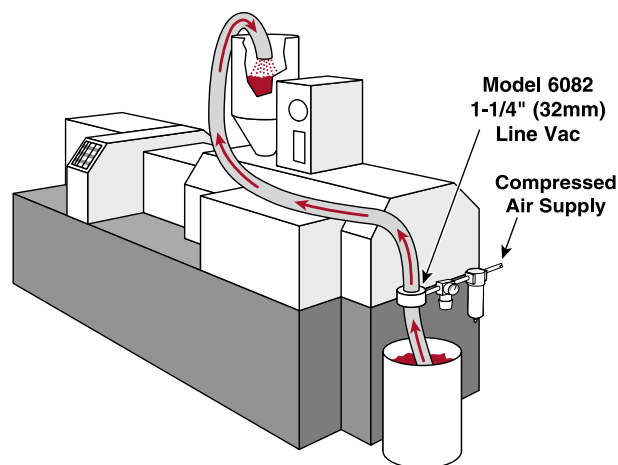

The Problem: Injection molding machines transform plastic pellets into various plastic products. The pellets are gravity fed from a hopper on top of the machine. The “bucket and ladder” method of replenishing the hopper was inefficient and expensive.

The Solution: A **Model 6982 1-1/4" (32mm) Line Vac Kit** was used to convey the pellets up to the hopper. The mounting bracket included with the kit was used to secure the Line Vac to the machine. A filter assured no contamination of the plastic material and a regulator controlled the plastic flow rate.

Comment: Unlike mechanical transfer systems that break down or wear out, the **Line Vac has no moving parts.** This low cost method of conveying also gives precise control of material flow into the hopper.

Line Vac for Matrix Removal from Labelling Application

The Problem: A manufacturer applies labels to their products. After they have been applied, there is a waste stream that is referred to as “the matrix”. The matrix is the release liner that labels are affixed to in bulk format prior to being used. The normal method for taking up this waste stream was to use a winder. However, after some amount of time, the winder inevitably becomes filled. Once full, the line is stopped and the winder is manually emptied. They needed a better way to dispose of the matrix.

The Solution: The **Line Vac** presents a unique advantage in that it can pull the matrix from the machine and convey it out to a waste receptacle. This requires no winder, no stopping the line and no emptying. This solution freed up personnel for other tasks and increased production. The compact design and powerful operation of the Line Vac

allowed it to be placed close to the generation of scrap, trim, or waste. Its powerful conveying capacity allowed it to transport the material to a remote and central location.

Comment: This application illustrates the versatility of the Line Vac product line. Commonly used for hopper loading products in the plastics industry, a Line Vac is also a strong performer for applications like waste/trim removal, assembly parts conveyance, blasting media recovery, gas sampling and chip removal. Its large variety of materials and sizes makes it well suited for industrial, pharmaceutical, laboratory, high temperature and corrosive environments. No moving parts or electricity assures maintenance free operation.



1" (25mm) Line Vacs remove and discard a label matrix.

Line Vac

Line Vac Only Models

Inlet/Outlet Diameter	Aluminum Line Vac Model	Type 303 Stainless Steel Line Vac Model	Type 316 Stainless Steel Line Vac Model	High Temperature Type 303 Stainless Steel Line Vac Model	High Temperature Type 316 Stainless Steel Line Vac Model
3/8" (10mm)	6078	6058	6058-316	N/A	N/A
1/2" (13mm)	6079	6059	6059-316	N/A	N/A
3/4" (19mm)	6080	6060	6060-316	HT6060	HT6060-316
1" (25mm)	6081	6061	6061-316	HT6061	HT6061-316
1-1/4" (32mm)	6082	6062	6062-316	HT6062	HT6062-316
1-1/2" (38mm)	6083	6063	6063-316	HT6063	HT6063-316
2" (51mm)	6084	6064	6064-316	HT6064	HT6064-316
2-1/2" (64mm)	6085	6065	6065-316	HT6065	HT6065-316
3" (76mm)	6086	6066	6066-316	HT6066	HT6066-316
4" (102mm)	6087	6067	N/A	N/A	N/A
5" (127mm)	6088	N/A	N/A	N/A	N/A

Line Vac Kit Models

Line Vac Kits - include the Line Vac, mounting bracket, filter separator and pressure regulator (with coupler).

Inlet/Outlet Diameter	Aluminum Line Vac Kit Model	Type 303 Stainless Steel Line Vac Kit Model	Type 316 Stainless Steel Line Vac Kit Model	High Temperature Type 303 Stainless Steel Line Vac Kit Model	High Temperature Type 316 Stainless Steel Line Vac Kit Model
3/8" (10mm)	6978	6958	6958-316	N/A	N/A
1/2" (13mm)	6979	6959	6959-316	N/A	N/A
3/4" (19mm)	6980	6960	6960-316	HT6960	HT6960-316
1" (25mm)	6981	6961	6961-316	HT6961	HT6961-316
1-1/4" (32mm)	6982	6962	6962-316	HT6962	HT6962-316
1-1/2" (38mm)	6983	6963	6963-316	HT6963	HT6963-316
2" (51mm)	6984	6964	6964-316	HT6964	HT6964-316
2-1/2" (64mm)	6985	6965	6965-316	HT6965	HT6965-316
3" (76mm)	6986	6966	6966-316	HT6966	HT6966-316
4" (102mm)	6987	6967	N/A	N/A	N/A
5" (127mm)	6988	N/A	N/A	N/A	N/A

Accessories

Model #	Description
6994	Mounting Bracket for 3/8" (10mm) and 1/2" (13mm) Line Vac Units
6995	Mounting Bracket for 3/4" (19mm) and 1" (25mm) Line Vac Units
6996	Mounting Bracket for 1-1/4" (32mm) and 1-1/2" (38mm) Line Vac Units
6997	Mounting Bracket for 2" (51mm), and 2-1/2" (64mm) Line Vac Units
6998	Mounting Bracket for 3" (76mm) and 4" (102mm) Line Vac Units
6999	Mounting Bracket for 5" (127mm) Line Vac Unit
9001	Auto Drain Filter Separator, 3/8 NPT, 65 SCFM (1,841 SLPM)
9032	Auto Drain Filter Separator, 1/2 NPT, 90 SCFM (2,549 SLPM)
9002	Auto Drain Filter Separator, 3/4 NPT, 220 SCFM (6,230 SLPM)
9005	Oil Removal Filter, 3/8 NPT, 15-37 SCFM (425-1,048 SLPM)
9006	Oil Removal Filter, 3/4 NPT, 50-150 SCFM (1,416-4,248 SLPM)
9008	Pressure Regulator with Gauge, 1/4 NPT, 50 SCFM (1,416 SLPM)
9033	Pressure Regulator with Gauge, 1/2 NPT, 100 SCFM (2,832 SLPM)
9009	Pressure Regulator with Gauge, 3/4 NPT, 220 SCFM (6,230 SLPM)

Hose is available in 10', 20', 30', 40' and 50' lengths. Select the hose model number (diameter) and indicate the length with a dash. Example: A Model 6931-20 is 1" ID Hose x 20' long.

6928-	Hose 3/8" ID
6929-	Hose 1/2" ID
6930-	Hose 3/4" ID
6931-	Hose 1" ID
6932-	Hose 1-1/4" ID
6933-	Hose 1-1/2" ID
6934-	Hose 2" ID
6935-	Hose 2-1/2" ID
6936-	Hose 3" ID

Air Operated Conveyors



(2) Model 6083 1-1/2" (38mm) Line Vacs convey rejected metal caps from a fluorescent lamp operation to a scrap bin.



1-1/4" (32mm) Line Vac is mounted on a burr removal tool to suction the plastic shavings and transport them to a waste container.



Threaded Line Vac™

Low cost conveyor uses ordinary pipe!

Ideal for long distance conveying!



Plastic color concentrate pellets are added to a plastic extrusion process.



What Is The Threaded Line Vac?

A fast, low cost way to convey:

- Plastic pellets
- Scrap trim
- Textiles
- Bulk solids
- Chips
- Paper
- Small parts
- Shavings
- Sawdust
- Granules

EXAIR's Threaded Line Vac air operated conveyors convert ordinary pipe into a powerful conveying system for parts, scrap, trim and other bulk materials. The Threaded Line Vac attaches easily to plumbing pipe couplers, making it easy to build a complete system using ordinary pipe and fittings available from any home center, hardware store or plumbers supply. Performance is the same as our standard Line Vac shown on page 143.

Threaded Line Vac conveyors are ideal for conveying large volumes of material over long distances. They eject a small amount of compressed air to produce a vacuum on one end with high output flows on the other. Response is instantaneous. Regulating the compressed air pressure provides infinite control of the conveying rate. Models from 3/8 NPT to 3 NPT are available in aluminum and stainless steel, which are suited to a wide variety of conveying applications. An optional mounting bracket permits easy mounting. No moving parts or electricity assures maintenance free operation.



A drawer slide manufacturer conveys ball bearings with the Model 141125 1-1/4 NPT Stainless Steel Threaded Line Vac to an assembly station.

Air Operated Conveyors

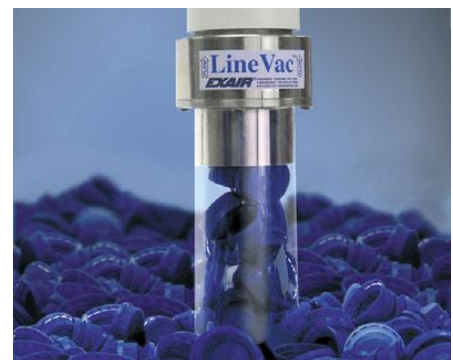

A special Threaded Line Vac has a smooth diameter for hose on the intake and threads on the exhaust that attach to PVC pipe.

Applications

- Hopper loading
- Fiber tensioning
- Material conveying
- Waste/trim removal
- Chip removal
- Part transfer
- Filling operations

Advantages

- Compact
- Quiet
- No moving parts
- Fits standard pipe
- Aluminum or stainless steel
- Available from stock
- High throughput capability

Threaded Line Vac

Dimensions

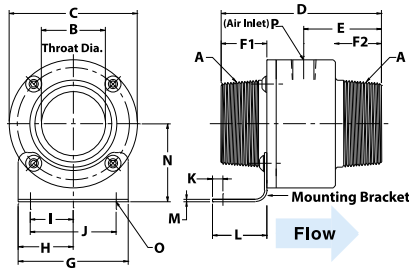

Threaded Line Vac Performance

Model	80 PSIG (5.5 BAR)		Air Consumption		Vacuum	
	SCFM	SLPM	"H ₂ O	kPa		
140038, 141038, 141038-316	5.60	158	-120	-29.9		
140050, 141050, 141050-316	7	198	-100	-24.9		
140075, 141075, 141075-316, HT141075, HT141075-316	10.70	303	-72	-18		
140100, 141100, 141100-316, HT141100, HT141100-316	14.70	416	-42	-11		
140125, 141125, 141125-316, HT141125, HT141125-316	25.90	733	-42	-11		
140150, 141150, 141150-316, HT141150, HT141150-316	33	934	-36.8	-9		
140200, 141200, 141200-316, HT141200, HT141200-316	45	1,274	-28.5	-7		
140250, 141250, 141250-316, HT141250, HT141250-316	58.50	1,656	-23.5	-6		
140300, 141300, 141300-316, HT141300, HT141300-316	68.50	1,939	-14.7	-4		

Threaded Line Vac Dimensions

Line Vac Models			A Pipe Size	B	C	D	E	F1	F2	G	H	I	J	K	L	M	N	O	P	
Alum.	303 St. St.	316 St. St.																		
140038	141038	141038-316	3/8 NPT	in	0.19	1.00	2.83	1.13	1.23	0.72	1.25	0.63	0.41	0.82	0.17	1.13	0.06	1.07	0.18	1/8 NPT
			mm	5	25	72	29	31	18	32	16	10	21	4	29	2	27	5		
140050	141050	141050-316	1/2 NPT	in	0.31	1.25	3.38	1.38	1.31	0.88	1.25	0.63	0.34	0.68	0.13	1.00	0.06	1.18	0.18	1/8 NPT
			mm	8	32	86	35	33	22	32	16	9	17	3	25	2	30	5		
140075	141075	141075-316	3/4 NPT	in	0.50	1.88	3.88	1.88	1	1	2	1	0.76	1.52	0.25	1.38	0.06	1.44	0.20	1/4 NPT
			mm	13	48	99	48	25	25	51	25	19	39	6	35	2	37	5		
140100	141100	141100-316	1 NPT	in	0.75	2.13	4.25	2.06	1.19	1.19	2	1	0.65	1.30	0.25	1.32	0.06	1.56	0.20	1/4 NPT
			mm	19	54	108	52	30	30	51	25	17	33	6	34	2	40	5		
140125	141125	141125-316	1-1/4 NPT	in	1	2.38	4.63	2.25	1.38	1.38	2.50	1.25	1	2	0.31	1.61	0.06	1.68	0.28	1/4 NPT
			mm	25	60	118	57	35	35	64	32	25	51	8	41	2	43	7		
140150	141150	141150-316	1-1/2 NPT	in	1.25	2.75	4.63	2.25	1.38	1.38	2.50	1.25	0.86	1.73	0.25	1.44	0.06	1.88	0.28	3/8 NPT
			mm	32	70	118	57	35	35	64	32	22	44	6	37	2	48	7		
140200	141200	141200-316	2 NPT	in	1.75	3.25	4.63	2.25	1.38	1.38	3	1.50	1.17	2.34	0.28	1.48	0.06	2.13	0.28	3/8 NPT
			mm	44	83	118	57	35	35	76	38	30	59	7	38	2	54	7		
140250	141250	141250-316	2-1/2 NPT	in	2.25	3.75	5.38	2.56	1.81	1.69	3	1.50	1	2	0.31	1.44	0.06	2.38	0.28	3/8 NPT
			mm	57	95	137	65	46	43	76	38	25	51	8	37	2	60	7		
140300	141300	141300-316	3 NPT	in	2.75	4.25	5.67	2.75	1.81	1.75	3.25	1.63	1.20	2.41	0.41	1.44	0.06	2.63	0.28	1/2 NPT
			mm	70	108	144	70	46	45	83	41	31	61	10	37	2	67	7		

Threaded Line Vac Dimensions

Line Vac Models			A Pipe Size	B	C	D	E	F1	F2	G	H	I	J	K	L	M	N	O	P	
Heavy Duty	High Temp 303 SS	High Temp 316 SS																		
151075	HT141075	HT141075-316	3/4 NPT	in	0.50	1.88	3.88	1.88	1	1	2	1	0.76	1.52	0.25	1.38	0.06	1.44	0.20	1/4 NPT
			mm	13	48	99	48	25	25	51	25	19	39	6	35	2	37	5		
151100	HT141100	HT141100-316	1 NPT	in	0.75	2.13	4.25	2.06	1.19	1.19	2	1	0.65	1.30	0.25	1.32	0.06	1.56	0.20	1/4 NPT
			mm	19	54	108	52	30	30	51	25	17	33	6	34	2	40	5		
151125	HT141125	HT141125-316	1-1/4 NPT	in	1	2.38	4.63	2.25	1.38	1.38	2.50	1.25	1	2	0.31	1.61	0.06	1.68	0.28	1/4 NPT
			mm	25	60	118	57	35	35	64	32	25	51	8	41	2	43	7		
151150	HT141150	HT141150-316	1-1/2 NPT	in	1.25	2.75	4.63	2.25	1.38	1.38	2.50	1.25	0.86	1.73	0.25	1.44	0.06	1.88	0.28	3/8 NPT
			mm	32	70	118	57	35	35	64	32	22	44	6	37	2	48	7		
151200	HT141200	HT141200-316	2 NPT	in	1.75	3.25	4.63	2.25	1.38	1.38	3	1.50	1.17	2.34	0.28	1.48	0.06	2.13	0.28	3/8 NPT
			mm	44	83	118	57	35	35	76	38	30	59	7	38	2	54	7		
151250	HT141250	HT141250-316	2-1/2 NPT	in	2.25	3.75	5.38	2.56	1.81	1.69	3	1.50	1	2	0.31	1.44	0.06	2.38	0.28	3/8 NPT
			mm	57	95	137	65	46	43	76	38	25	51	8	37	2	60	7		
151300	HT141300	HT141300-316	3 NPT	in	2.75	4.25	5.67	2.75	1.81	1.75	3.25	1.63	1.20	2.41	0.41	1.44	0.06	2.63	0.28	1/2 NPT
			mm	70	108	144	70	46	45	83	41	31	61	10	37	2	67	7		

Threaded Line Vac Models

Threaded Line Vac Only

Inlet/Outlet Thread Size	Aluminum Threaded Line Vac Only Model	Type 303 Stainless Steel Threaded Line Vac Only Model	High Temperature Type 303 Stainless Steel Threaded Line Vac Only Model	Type 316 Stainless Steel Threaded Line Vac Only Model	High Temperature Type 316 Stainless Steel Threaded Line Vac Only Model
3/8 NPT	140038	141038	N/A	141038-316	N/A
1/2 NPT	140050	141050	N/A	141050-316	N/A
3/4 NPT	140075	141075	HT141075	141075-316	HT141075-316
1 NPT	140100	141100	HT141100	141100-316	HT141100-316
1-1/4 NPT	140125	141125	HT141125	141125-316	HT141125-316
1-1/2 NPT	140150	141150	HT141150	141150-316	HT141150-316
2 NPT	140200	141200	HT141200	141200-316	HT141200-316
2-1/2 NPT	140250	141250	HT141250	141250-316	HT141250-316
3 NPT	140300	141300	HT141300	141300-316	HT141300-316

Threaded Line Vac Kit Models

Threaded Line Vac Kits - include the Line Vac, mounting bracket, filter separator and pressure regulator (with coupler).

Inlet/Outlet Thread Size	Aluminum Threaded Line Vac Kit Model	Type 303 Stainless Steel Threaded Line Vac Kit Model	High Temperature Type 303 Stainless Steel Threaded Line Vac Kit Model	Type 316 Stainless Steel Threaded Line Vac Kit Model	High Temperature Type 316 Stainless Steel Threaded Line Vac Kit Model
3/8 NPT	142038	143038	N/A	143038-316	N/A
1/2 NPT	142050	143050	N/A	143050-316	N/A
3/4 NPT	142075	143075	HT143075	143075-316	HT143075-316
1 NPT	142100	143100	HT143100	143100-316	HT143100-316
1-1/4 NPT	142125	143125	HT143125	143125-316	HT143125-316
1-1/2 NPT	142150	143150	HT143150	143150-316	HT143150-316
2 NPT	142200	143200	HT143200	143200-316	HT143200-316
2-1/2 NPT	142250	143250	HT143250	143250-316	HT143250-316
3 NPT	142300	143300	HT143300	143300-316	HT143300-316

Air Operated
Conveyors

Accessories

Model #	Description
6994	Mounting Bracket for 3/8 NPT and 1/2 NPT Threaded Line Vac Units
6995	Mounting Bracket for 3/4 NPT and 1 NPT Threaded Line Vac Units
6996	Mounting Bracket for 1-1/4 NPT and 1-1/2 NPT Threaded Line Vac Units
6997	Mounting Bracket for 2 NPT and 2-1/2 NPT Threaded Line Vac Units
6998	Mounting Bracket for 3 NPT Line Vac Units
9001	Auto Drain Filter Separator, 3/8 NPT, 65 SCFM (1,841 SLPM)
9005	Oil Removal Filter, 3/8 NPT, 15-37 SCFM (425-1,048 SLPM)
9008	Pressure Regulator with Gauge, 1/4 NPT, 50 SCFM (1,416 SLPM)



Threaded Line Vac Kits include the Threaded Line Vac, mounting bracket, filter separator and pressure regulator (with coupler).

Heavy Duty Line Vac™

Our most powerful Line Vac moves high volumes of material and resists wear!

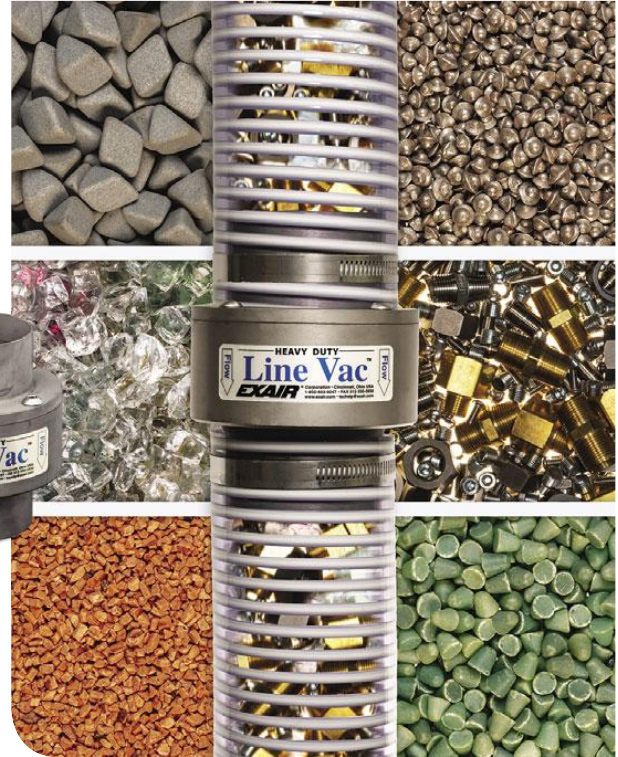

What Is The Heavy Duty Line Vac?

The Heavy Duty Line Vac is EXAIR's most powerful conveyor. The appearance is similar to the standard Line Vac but performance has been boosted dramatically. The Heavy Duty Line Vac has been engineered to convey materials over longer vertical and horizontal distances. The hardened alloy construction helps prevent premature wear that could occur with ordinary aluminum or stainless steel Line Vacs.

Why The Heavy Duty Line Vac?

Many applications require that materials be transported over longer distances. The Heavy Duty Line Vac can move more material over longer lengths. They have been designed for rugged, industrial applications.

The table below gives a quick comparison of our Light Duty Line Vac, standard Line Vac, and the Heavy Duty Line Vac models. For comparison, the test shows the 2" (51mm) model of each style conveying the same material over various lengths. Heavy Duty Line Vac conveys more material in less time.

	Rock Salt Conveying Rate Comparison	
	100 Feet (30.5m)	200 Feet (61m)
Model 130200 2" (51mm) Light Duty Line Vac	166 lbs/hr. (75.3 kg/hr.)	N/A
Model 6084 2" (51mm) Line Vac	334 lbs/hr. (151.5 kg/hr.)	85 lbs/hr. (38.6 kg/hr.)
Model 150200 2" (51mm) Heavy Duty Line Vac	524 lbs/hr. (237.7 kg/hr.)	200 lbs/hr. (90.7 kg/hr.)

Horizontal conveying tested at 80 PSIG (5.5 BAR)

Applications

- Hopper loading
- Fiber tensioning
- Material conveying
- Waste/trim removal
- Chip removal
- Part transfer
- Filling operations

Advantages

- Hardened alloy construction
- Highest throughput capability
- Compact
- Quiet
- No moving parts
- Fits standard hose, tube and pipe
- Available from stock

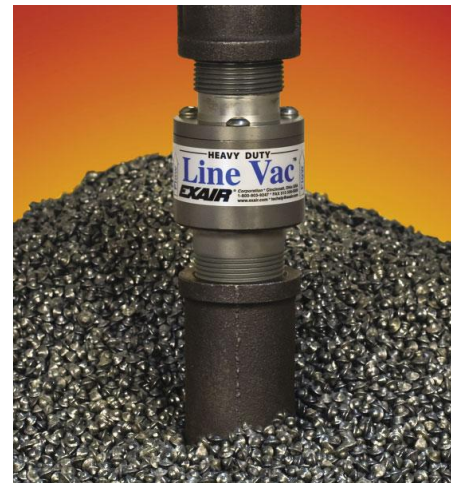

The hardened alloy construction of the Heavy Duty Threaded Line Vac resists wear when conveying abrasive steel shot.



Metal parts are conveyed with the Model 150200 2" (51mm) Heavy Duty Line Vac as they drop off the edge of the conveyor.

Heavy Duty Line Vac



Heavy Duty Threaded Line Vac

EXAIR's Heavy Duty Threaded Line Vac air operated conveyors convert ordinary pipe into a powerful conveying system for parts, scrap, trim and other bulk materials. The engineered Heavy Duty Threaded Line Vac attaches easily to ordinary NPT pipe and fittings available from any home center, hardware store or plumbers supply. With its hardened alloy construction, the Heavy Duty Threaded Line Vac withstands premature wear which could occur with aluminum and stainless steel.

Heavy Duty Line Vac Performance

Model	80 PSIG (5.5 BAR)		Size		Air Consumption		Vacuum	
	in	mm	SCFM	SLPM	"H ₂ O	kPa		
150075, 151075	0.75	19	26	736	-144	-36		
150100, 151100	1	25	35	991	-105	-26		
150125, 151125	1.25	32	49	1,388	-83	-21		
150150, 151150	1.50	38	55	1,557	-60	-15		
150200, 151200	2	51	75	2,124	-42	-10		
150250, 151250	2.50	64	90	2,548	-28	-7		
150300, 151300	3	76	108	3,058	-20	-5		



Dimensions

For Heavy Duty Line Vac Dimensions, see:
 Line Vac.....pg 142
 Threaded Line Vacpg 148

Heavy Duty Line Vac Models					
Heavy Duty Line Vac Only					
Heavy Duty Line Vac Kits - include the Line Vac, mounting bracket, filter separator and pressure regulator (with coupler).					
Inlet/Outlet Diameter	Heavy Duty Line Vac Only Model	Heavy Duty Line Vac Kit Model	Inlet/Outlet Thread Size	Heavy Duty Threaded Line Vac Only Model	Heavy Duty Threaded Line Vac Kit Model
3/4" (19mm)	150075	152075	3/4 NPT	151075	153075
1" (25mm)	150100	152100	1 NPT	151100	153100
1-1/4" (32mm)	150125	152125	1-1/4 NPT	151125	153125
1-1/2" (38mm)	150150	152150	1-1/2 NPT	151150	153150
2" (51mm)	150200	152200	2 NPT	151200	153200
2-1/2" (64mm)	150250	152250	2-1/2 NPT	151250	153250
3" (76mm)	150300	152300	3 NPT	151300	153300

Accessories

Model #	Description
6995	Mounting Bracket for 3/4" (19mm) and 1" (25mm) Line Vac Units
6996	Mounting Bracket for 1-1/4" (32mm) and 1-1/2" (38mm) Line Vac Units
6997	Mounting Bracket for 2" (51mm) and 2-1/2" (64mm) Line Vac Units
6998	Mounting Bracket for 3" (76mm) Line Vac Units
9001	Auto Drain Filter Separator, 3/8 NPT, 65 SCFM (1,841 SLPM)
9032	Auto Drain Filter Separator, 1/2 NPT, 90 SCFM (2,549 SLPM)
9002	Auto Drain Filter Separator, 3/4 NPT, 220 SCFM (6,230 SLPM)
9005	Oil Removal Filter, 3/8 NPT, 15-37 SCFM (425-1,048 SLPM)
9006	Oil Removal Filter, 3/4 NPT, 50-150 SCFM (1,416-4,248 SLPM)
9008	Pressure Regulator with Gauge, 1/4 NPT, 50 SCFM (1,416 SLPM)
9033	Pressure Regulator with Gauge, 1/2 NPT, 100 SCFM (2,832 SLPM)
9009	Pressure Regulator with Gauge, 3/4 NPT, 220 SCFM (6,230 SLPM)

Air Operated Conveyors

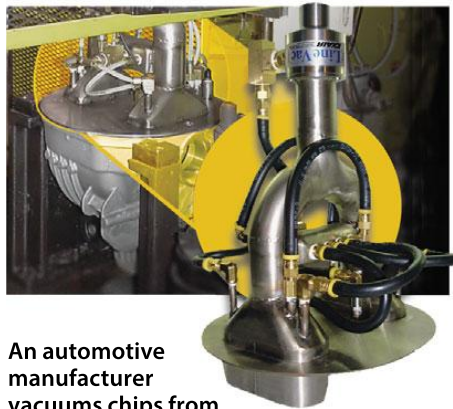

An automotive manufacturer vacuums chips from drive train differentials with a Model 150200 2" (51mm) Heavy Duty Line Vac.



Heavy Duty Line Vac Kits include a Heavy Duty Line Vac, mounting bracket, filter separator and pressure regulator (with coupler).

If you have special requirements, please contact an Application Engineer to discuss the application.

Hose is available in 10', 20', 30', 40' and 50' lengths. Select the hose model number (diameter) and indicate the length with a dash. Example: A Model 6931-20 is 1" ID Hose x 20' long.

6930-	Hose 3/4" ID
6931-	Hose 1" ID
6932-	Hose 1-1/4" ID
6933-	Hose 1-1/2" ID
6934-	Hose 2" ID
6935-	Hose 2-1/2" ID
6936-	Hose 3" ID

Sanitary Flange Line Vac™

Convey materials, parts, waste - with easy disassembly and cleanup!



What Is The Sanitary Flange Line Vac?

EXAIR's Sanitary Flange Line Vac is the best way to convey materials in systems which require frequent or mandatory cleaning. The Sanitary Flange Line Vac fits within your current sanitary flange piping system and converts it into a conveyor for waste, parts and bulk materials.

Why The Sanitary Flange Line Vac?

When your piping system requires sanitary flanges, which make it easy to dismantle and clean its components, the Sanitary Flange Line Vac will suit your needs. They are made from Type 316SS to provide superior corrosion resistance and cleanliness. These flanged Line Vacs limit entrapment areas where bacteria can grow and the clamp style sanitary flanges are compatible with ISO 2852. Sanitary Flange Line Vacs are designed with the same performance characteristics of EXAIR's standard and

Threaded Line Vacs which makes them a versatile solution for your conveying needs. Conveying rates are easy to control by regulating the compressed air supply pressure.

The Sanitary Flange Line Vacs are available from stock in four common flange sizes, 1-1/2" (38mm), 2" (51mm), 2-1/2" (64mm) and 3" (76mm). All metal parts are made from Type 316SS. No moving parts or electricity assures maintenance free operation.

Sanitary Flange Line Vac Performance

80 PSIG (5.5 BAR)		Size		Air Consumption		Vacuum	
Model	in	mm	SCFM	SLPM	"H ₂ O	kPa	
161150-316	1.5	38	33	934	-36.8	-9	
161200-316	2	51	45	1,274	-28.5	-7	
161250-316	2.5	64	58.5	1,657	-23.5	-6	
161300-316	3	76	68.5	1,939	-14.7	-4	

Horizontal conveying tested at 80 PSIG (5.5 BAR)

Applications

- Material conveying
- Part transfer
- Waste/trim removal
- Hopper loading
- Filling operations
- Chip removal
- Fiber tensioning

Advantages

- ISO 2852 compatible
- Type 316SS
- Fits standard sanitary flanges
- Four sizes available from stock
- No moving parts
- Compact
- High throughput capability
- Quiet



Dimensions

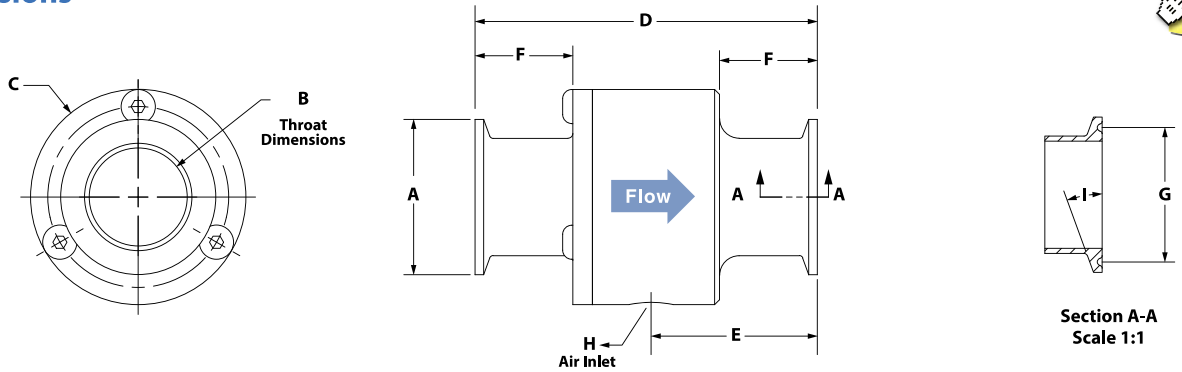

Sanitary Flange Line Vac Dimensions										
Sanitary Flange Line Vac Models		A	B	C	D	E	F	G	H (air inlet)	I
161150-316	in	2	1.25	2.75	4.38	2.13	1.25	1.69	1/4 NPT	20°
	mm	51	32	70	111	54	32	43		
161200-316	in	2.52	1.75	3.25	4.38	2.13	1.25	2.22	3/8 NPT	20°
	mm	64	44	83	111	54	32	56		
161250-316	in	3.05	2.25	3.75	4.38	2.13	1.25	2.78	3/8 NPT	20°
	mm	77	57	95	111	54	32	71		
161300-316	in	3.58	2.75	4.25	5.63	2.75	1.75	3.28	1/2 NPT	21.3°
	mm	91	70	108	143	70	44	83		

Sanitary Flange Line Vac Models		
Sanitary Flange Line Vac Only		
Sanitary Flange Line Vac Kits - include the Line Vac, mounting bracket, filter separator and pressure regulator (with coupler).		
Inlet/Outlet Diameter	Sanitary Flange Line Vac Only Model	Sanitary Flange Line Vac Kit Model
1-1/2" (19mm)	161150-316	163150-316
2" (25mm)	161200-316	163200-316
2-1/2" (32mm)	161250-316	163250-316
3" (38mm)	161300-316	163300-316

Accessories	
Model #	Description
9001	Auto Drain Filter Separator, 3/8 NPT, 65 SCFM (1,841 SLPM)
9002	Auto Drain Filter Separator, 3/4 NPT, 220 SCFM (6,230 SLPM)
9005	Oil Removal Filter, 3/8 NPT, 15-37 SCFM (425-1,048 SLPM)
9006	Oil Removal Filter, 3/4 NPT, 50-150 SCFM (1,416-4,248 SLPM)
9008	Pressure Regulator with Gauge, 1/4 NPT, 50 SCFM (1,416 SLPM)
9009	Pressure Regulator with Gauge, 3/4 NPT, 220 SCFM (6,230 SLPM)

Air Operated Conveyors

Line Vac Drum Cover

Line Vac Drum Cover

EXAIR's fine mesh non-woven Drum Cover is built to fit over the top of 55 or 30 gallon drums. The breathable material allows the air from a Line Vac air operated conveyor to circulate, whether moving material in or out of the drum. The cover prevents contamination of your material and keeps material from escaping the drum which keeps your work environment cleaner and safer. Since it is fabricated to fit 55 or 30 gallon drums, it is the simplest of solutions when needing a containment vessel for your transferred scrap, trim, waste, parts, chips or pellets. It is suitable for Line Vac conveyance hoses from 3/4" through 3.4" outside diameters and comes complete with hose clamps and a durable spring buckle strap for quick and easy installation.



Line Vac Drum Cover

Model #	Description
6850	Drum Cover

If you have special requirements, please contact an Application Engineer to discuss the application.

Light Duty Line Vac™

An effective way to convey small volumes of material over short distances!

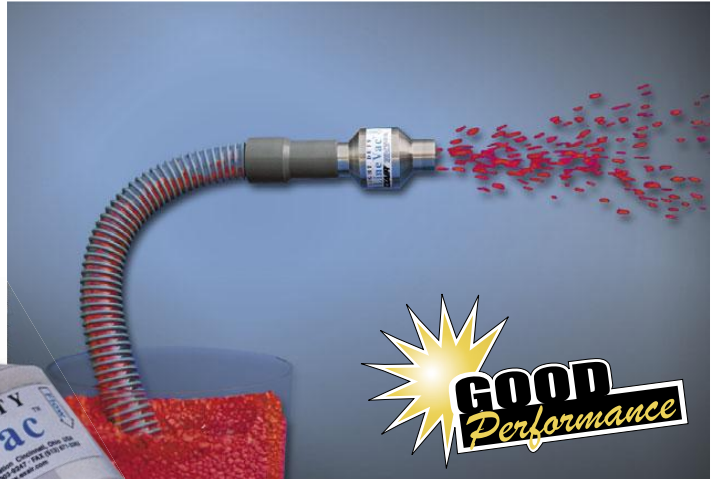

What Is The Light Duty Line Vac?

EXAIR's Light Duty Line Vac is the ideal way to convey small volumes of materials over short distances. Like the Line Vac shown on page 141, the Light Duty Line Vac converts an ordinary hose or tube into a conveyor for scrap, trim and bulk materials.

Why The Light Duty Line Vac?

When lower throughputs at short distances are desired, the Light Duty Line Vac is a good choice. This simplified design utilizes a two-part threaded construction to provide effective conveying at a lower cost. Air consumption is reduced to a volume appropriate for moving small volumes of material at short distances. Conveying rates are easy to control by regulating the compressed air supply pressure.

The Light Duty Line Vac features inlet and outlet diameters common to hose and tube sizes. Eight sizes for diameters from 3/4" to 6" (19 to 152mm) are available. Standard construction is aluminum. (For corrosion resistant stainless steel models that are suitable for high temperature and food service, please see Line Vac models on page 146.) No moving parts or electricity assures maintenance free operation. (If higher conveying rates or mounting brackets are desired, see the Line Vac models on page 146.)



The low cost Model 130200 2" (51mm) Light Duty Line Vac conveys fibers to fill pillows, stuffed animals, diapers, etc.

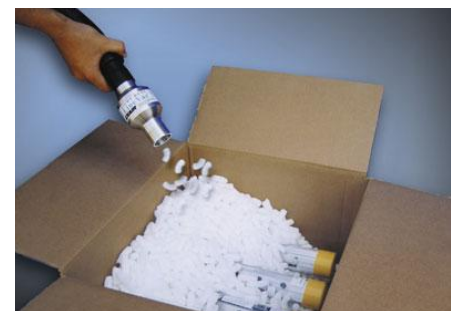

A Model 130125 1-1/4" (32mm) Light Duty Line Vac can fill or empty the packing peanuts from shipping cartons.

Applications

- Hopper loading
- Fiber tensioning
- Material conveying
- Waste/trim removal
- Chip removal
- Part transfer
- Filling operations

Advantages

- Compact
- Quiet
- No moving parts
- Fits standard hose or tube
- Aluminum
- Eight sizes
- Moderate throughput capability

Light Duty Line Vac



Light Duty Line Vacs are available in eight sizes for diameters from 3/4" to 6" (19 to 152mm).

Light Duty Line Vac Dimensions

Model #		A	B	C	D	E	F	G
130075	in	0.75	0.50	1.88	4.53	2.31	1.06	1/4
	mm	19	13	48	115	59	27	NPT
130100	in	1	0.75	2.13	4.53	2.41	1.06	1/4
	mm	25	19	54	115	61	27	NPT
130125	in	1.25	1	2.38	4.53	2.41	1.06	1/4
	mm	32	25	60	115	61	27	NPT
130150	in	1.50	1.25	2.75	4.63	2.41	1.06	3/8
	mm	38	32	70	117	61	27	NPT
130200	in	2	1.75	3.25	4.66	2.47	1.06	3/8
	mm	51	45	83	118	63	27	NPT
130300	in	3	2.75	4.25	5.06	2.75	1.06	3/8
	mm	76	70	108	129	70	27	NPT
130400	in	4	3.75	5.25	5.06	2.75	1.06	1/2
	mm	102	95	133	129	70	27	NPT
130600	in	6	5.75	7.38	5.56	2.88	1.06	1/2
	mm	152	146	187	141	73	27	NPT

Light Duty Line Vac Systems

Light Duty Line Vac Models

Light Duty Line Vac Only

Light Duty Line Vac Kits - include the Light Duty Line Vac, filter separator and pressure regulator (with coupler).

Inlet/Outlet Diameter	Light Duty Line Vac Only Model	Light Duty Line Vac Kit Model
3/4" (19mm)	130075	132075
1" (25mm)	130100	132100
1-1/4" (32mm)	130125	132125
1-1/2" (38mm)	130150	132150
2" (51mm)	130200	132200
3" (76mm)	130300	132300
4" (102mm)	130400	132400
6" (152mm)	130600	132600

Accessories

Model #	Description
9001	Auto Drain Filter Separator, 3/8 NPT, 65 SCFM (1,841 SLPM)
9002	Auto Drain Filter Separator, 3/4 NPT, 220 SCFM (6,230 SLPM)
9005	Oil Removal Filter, 3/8 NPT, 15-37 SCFM (425-1,048 SLPM)
9006	Oil Removal Filter, 3/4 NPT, 50-150 SCFM (1,416-4,248 SLPM)
9008	Pressure Regulator with Gauge, 1/4 NPT, 50 SCFM (1,416 SLPM)
9009	Pressure Regulator with Gauge, 3/4 NPT, 220 SCFM (6,230 SLPM)

Hose is available in 10', 20', 30', 40' and 50' lengths. Select the hose model number (diameter) and indicate the length with a dash. Example: A Model 6931-20 is 1" ID Hose x 20' long.

6930-	Hose 3/4" ID
6931-	Hose 1" ID
6932-	Hose 1-1/4" ID
6933-	Hose 1-1/2" ID
6934-	Hose 2" ID
6936-	Hose 3" ID



Kits include a Light Duty Line Vac, filter separator and pressure regulator (with coupler).

DOWNLOAD drawings at EXAIR.com

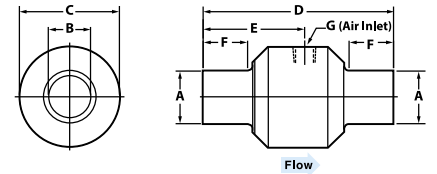

Light Duty Performance

Model #	80 PSIG (5.5 BAR) Air Consumption	
	SCFM	SLPM
130075	7.30	207
130100	10.70	303
130125	14.70	501
130150	20	566
130200	27.50	778
130300	45	1,274
130400	58.50	1,656
130600	80.20	2,270



Air Operated Conveyors

PVC hose is available in lengths up to 50' (15.2m) and diameters up to 3" (76mm).

GO GREEN **SAVE MONEY**

Order EXAIR's EFC™ electronic flow control to minimize compressed air use. See page 7 for details.

ORDER ONLINE
at EXAIR.com

Order Direct
We Ship From Stock

EXAIR® Standards Compliance

As the leader in standards compliance, EXAIR's products come with more than engineered performance, peak efficiency, the best technical knowledge and unmatched customer service... .

EXAIR is dedicated to providing products that have been manufactured to meet the strict requirements of the following standards. These standards provide confidence that you are receiving reliable, high quality products which will perform as stated within the performance charts provided.

Our products meet or exceed the strict safety standards of OSHA and the European Union to ensure the safety of your personnel. Many of these standards will allow your products a smoother transaction when selling your products into international markets.

OSHA and CE Compliance: EXAIR compressed air products comply with OSHA's Safety Requirements (29 CFR 1910.242(b)), the EU General Product Safety Directive (2001/95/EC) and meet the noise limitation requirements (29 CFR-1910.95(a)), of the EU Machinery Directive (2006/42/EC). EXAIR's Electronic Flow Control and Electronic Temperature Control meet the low voltage standards of the EU Low Voltage Directive (2006/95/EC). Some EXAIR products display the CE mark where there are applicable directives. All sound level measurements are taken at 3 feet from product.



RoHS: Electrical portions of EXAIR's Static Eliminators, EFC, ETC, Digital Flowmeter solenoid valves, and thermostats comply with the RoHS (Restriction of Hazardous Substances) Directive 2011/65/EU, including the amendment outlined in the European Commission decision L 214/65.



Conflict Mineral Free: Look for this symbol to designate conflict mineral free products throughout our catalog. EXAIR supports Section 1502 of the Dodd-Frank Wall Street Reform and Consumer Protection Act. We are committed to compliance with the conflict minerals rule in order to curb the illicit trade of tin, tantalum, tungsten and gold in the DRC region. EXAIR is using the CMRT 4.20 template to document our supply chain and commitment to conflict free products.



Reach: Per Regulation (EC) No 1907/2006 Title I, Article 3, paragraph 3, the European Union has recently enacted legislation to register chemicals and substances imported into the EU to ensure a high level of protection of human health and the environment.



Per Title II, Article 7, paragraph 1, articles (products) must be registered when a substance is intended to be released under normal or reasonably foreseeable conditions of use and it is present in those articles in quantities totaling over 1 metric ton per producer or importer per year. Registration of EXAIR products is not required since they do not contain substances that are intentionally released.